

TURNSTAR



RELIABLE ★ DURABLE ★ GUARANTEED

USER MANUAL



HALF HEIGHT & THREE-QUARTER TURNSTILE

INDUSTRIAL TYPE

CONTENTS

1. FOREWORD 5

2. GENERAL DRAWINGS 6

Figure 1: Single 4-Arm Industrial Half Height Turnstile 6

Figure 2: Single 3-Arm Industrial Half Height Turnstile 7

Figure 3: Double 4-Arm Industrial Half Height Turnstile..... 8

Figure 4: Double 3-Arm Industrial Half Height Turnstile..... 9

Figure 5: Single 4-Arm Industrial ¾ Height Turnstile..... 10

Figure 6: Single 3-Arm Industrial ¾ Height Turnstile..... 11

Figure 7: Double 4-Arm Industrial ¾ Height Turnstile 12

Figure 8: Double 3-Arm Industrial ¾ Height Turnstile 13

3. GENERAL ASSEMBLY NOTES 14

4. SINGLE PARTS & ASSEMBLY 15

Figure 9: Single Frame Assembly 15

Figure 10: Single Turnstile Plinth..... 16

Figure 11: Sleeve and rotor on bearing pin 17

Figure 12: Mechanism & Rotor Connection 18

Figure 13: Single Half Height Exploded..... 19

Figure 14: Detail of Exploded Parts 20

Table 1: Single Turnstile Parts 20

5. DOUBLE PARTS & ASSEMBLY 22

Figure 15: Double Frame Assembly 22

Figure 16: Double Turnstile Plinth 23

Figure 17: Double Turnstile Exploded Parts 1..... 24

Figure 18: Double Turnstile Exploded Parts 2..... 25

Table 2: Double Turnstile Parts 25

6. FURTHER ROTOR ASSEMBLY INFORMATION 27

Figure 19: Views on top disk & base bearing 28

7. INSTALLATION 29

8. CONTROL PANEL & LOGIC 30

Figure 20: Turnstile control panel components 30

9. TURNSTILE LOGIC TYPES 31

Figure 21: Grey Plug-in Logic (TURTL373) 31

Figure 22: Base of Grey Plug-in Logic (TURTL373) 32

Table 3: TURTL373 Logic Dipswitch Settings 32

Figure 23: Blue Plug-in Logic (TL300TUR) 33

Table 4: TL300TUR Logic Dipswitch Settings 33

10. WIRING DIAGRAMS 34

Figure 24: Wiring Diagram for Full Height Turnstile 34

Figure 25: Wiring Diagram for FH Turnstile with Battery Backup 35

11. STANDARD FACTORY SETUP 36

12. MAINTENANCE 37

13. FAIL-SECURE AND FAIL-SAFE 37

Figure 26: Solenoid in Fail-secure arrangement 37

Figure 27: Solenoid in Fail-safe arrangement 38

Figure 28: Solenoid assembly – Fail-secure 39

..... 40

Figure 29: Solenoid assembly – Fail-safe 40

14. MAINTENANCE 41

Table 5: Recommended Maintenance Procedure 41

15. CLEANING 42

Table 6: Recommended Cleaning Frequency..... 42

16. SPARE PARTS 43

Table 7: Spare Parts List 43

17. FAULT FINDING 44

1. FOREWORD

- 1.1. No part of this module may be reproduced in any form, photocopy or otherwise, without the written permission of Turnstar systems. All information, drawings and diagrams may not be made public or shared with a third party.
- 1.2. In the event of any breach of abovementioned copyright, the rights of Turnstar systems will be strictly enforced.
- 1.3. The information contained herein remains the intellectual property of Turnstar systems.

2. GENERAL DRAWINGS

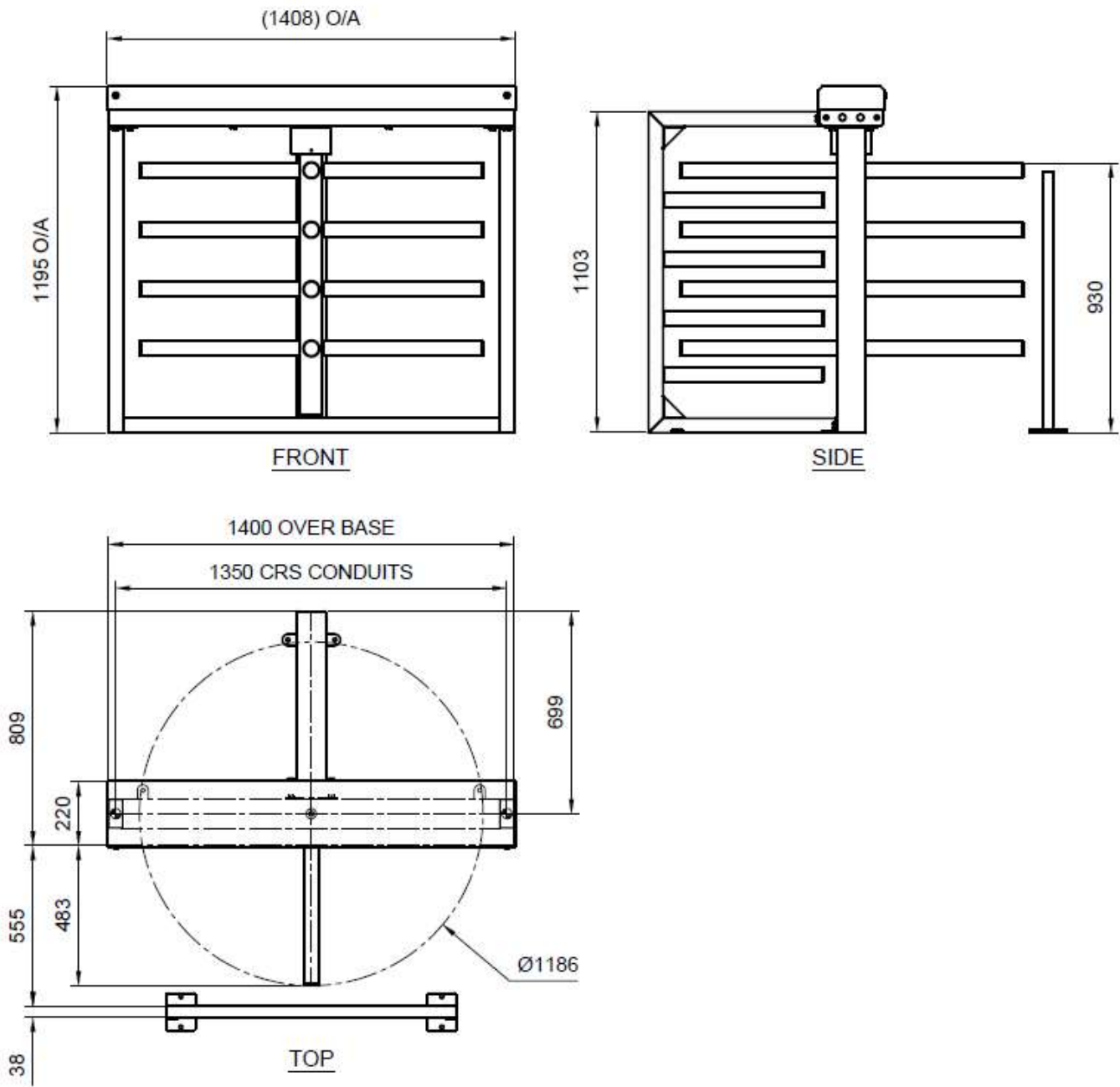

Figure 1: Single 4-Arm Industrial Half Height Turnstile

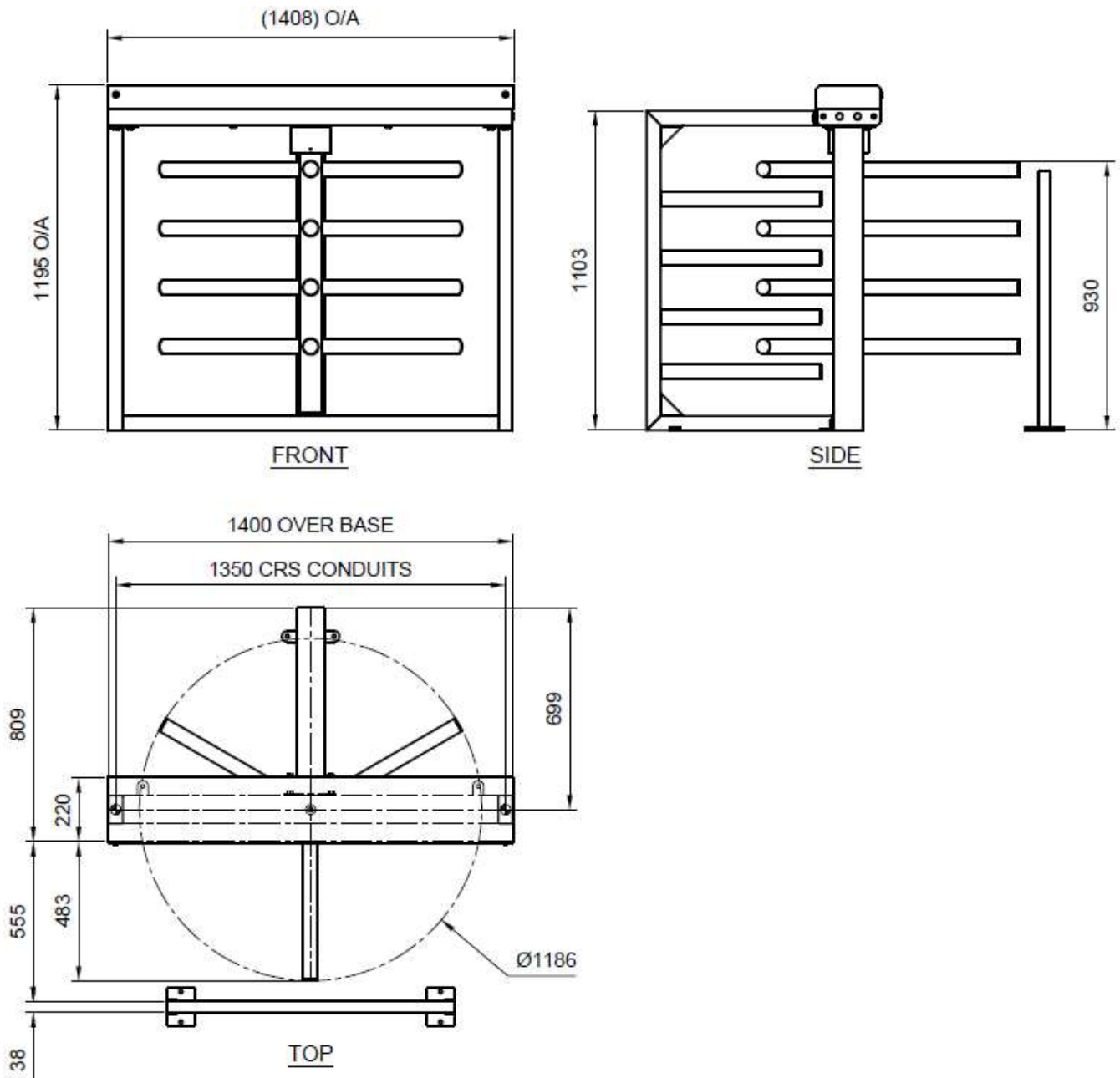

Figure 2: Single 3-Arm Industrial Half Height Turnstile

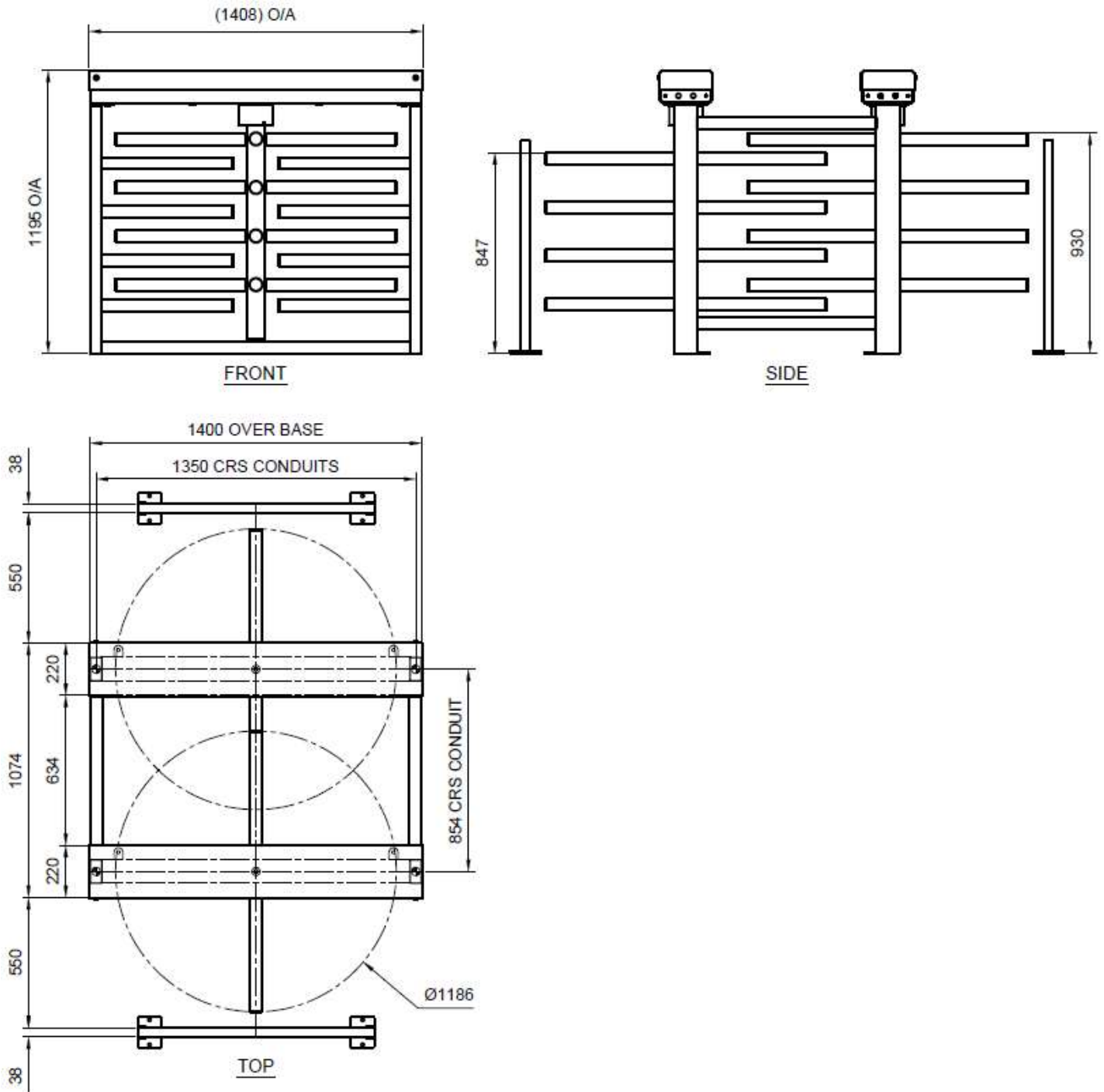

Figure 3: Double 4-Arm Industrial Half Height Turnstile

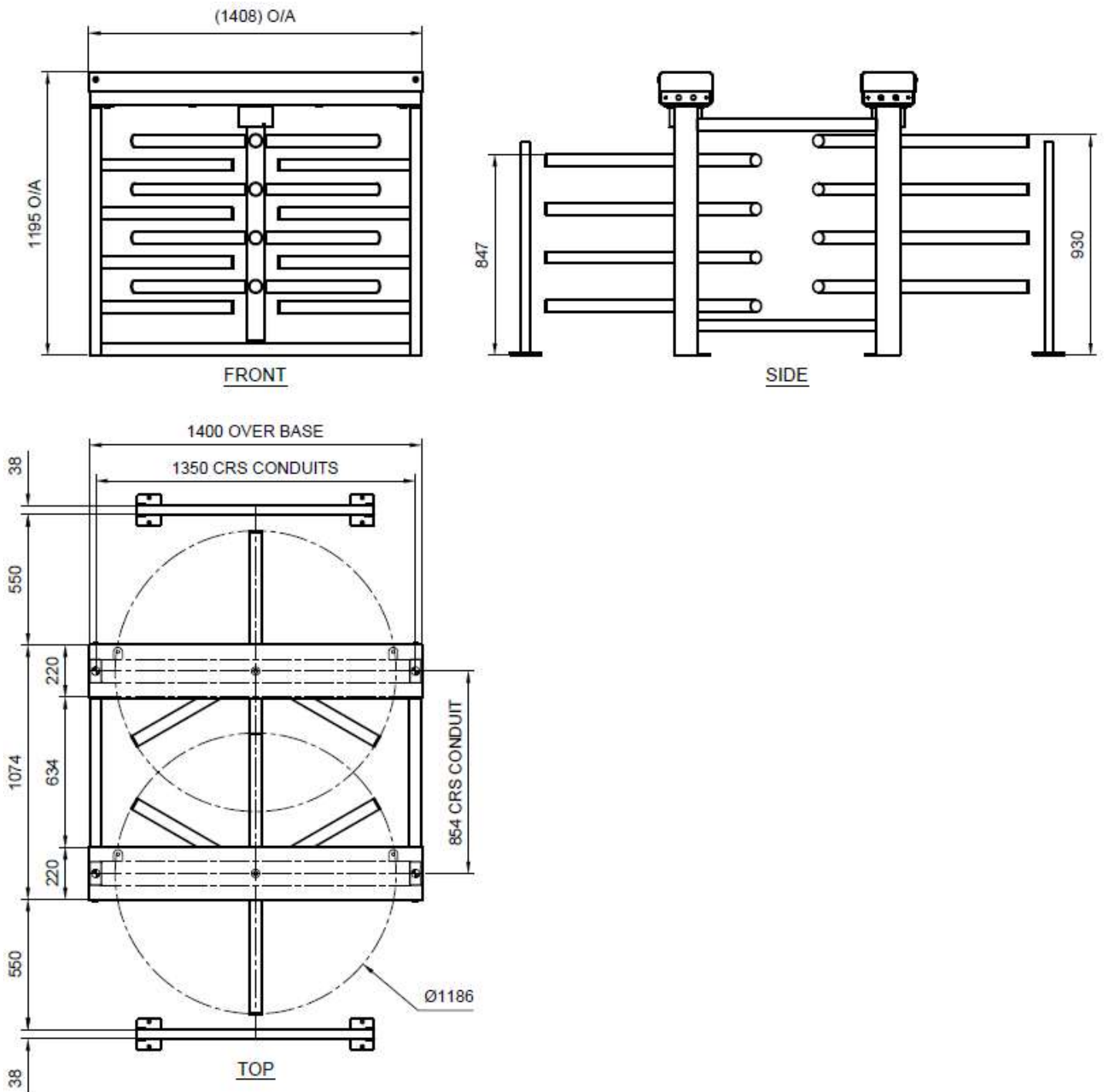

Figure 4: Double 3-Arm Industrial Half Height Turnstile

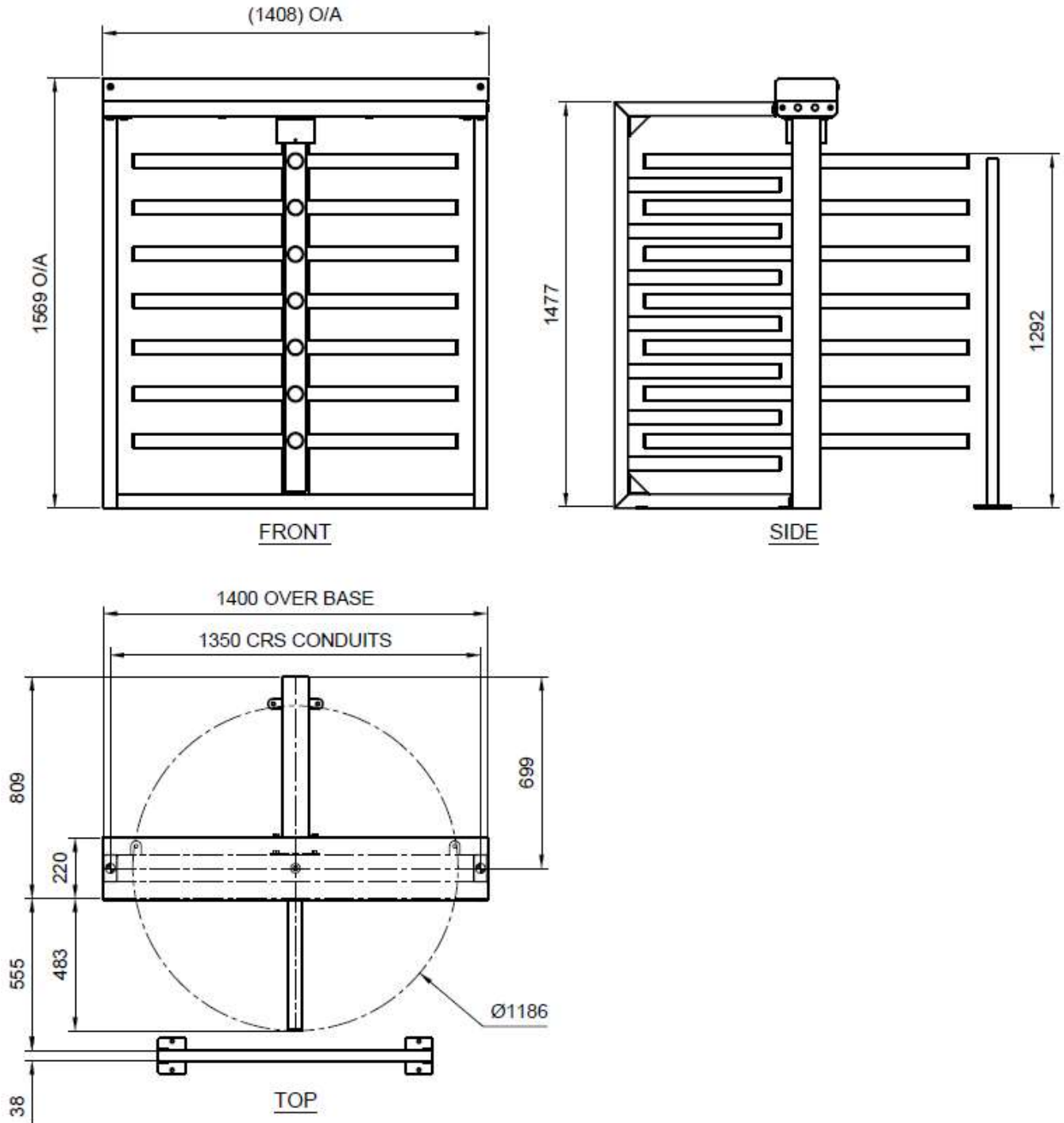

Figure 5: Single 4-Arm Industrial 3/4 Height Turnstile

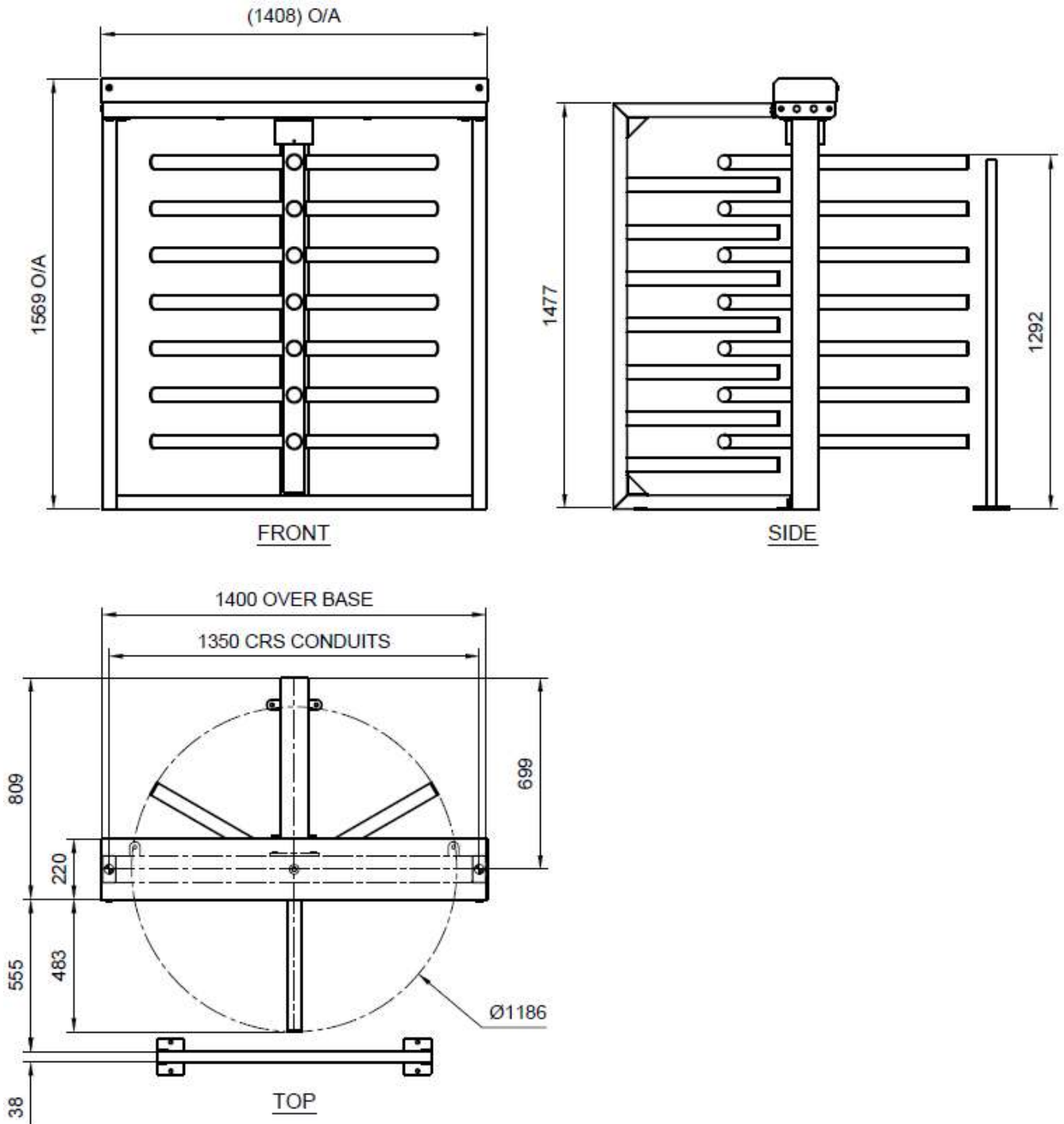

Figure 6: Single 3-Arm Industrial 3/4 Height Turnstile

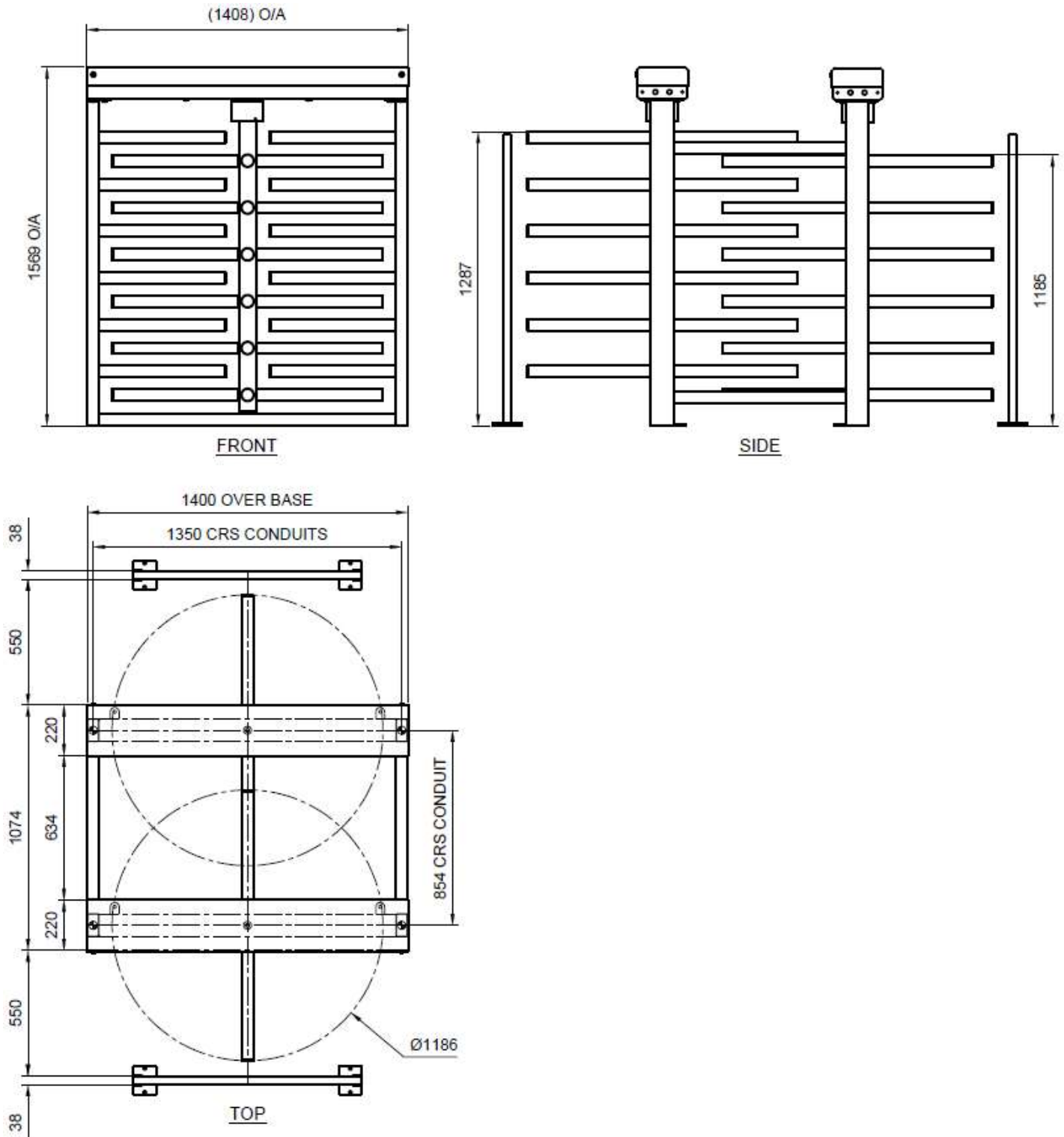

Figure 7: Double 4-Arm Industrial 3/4 Height Turnstile

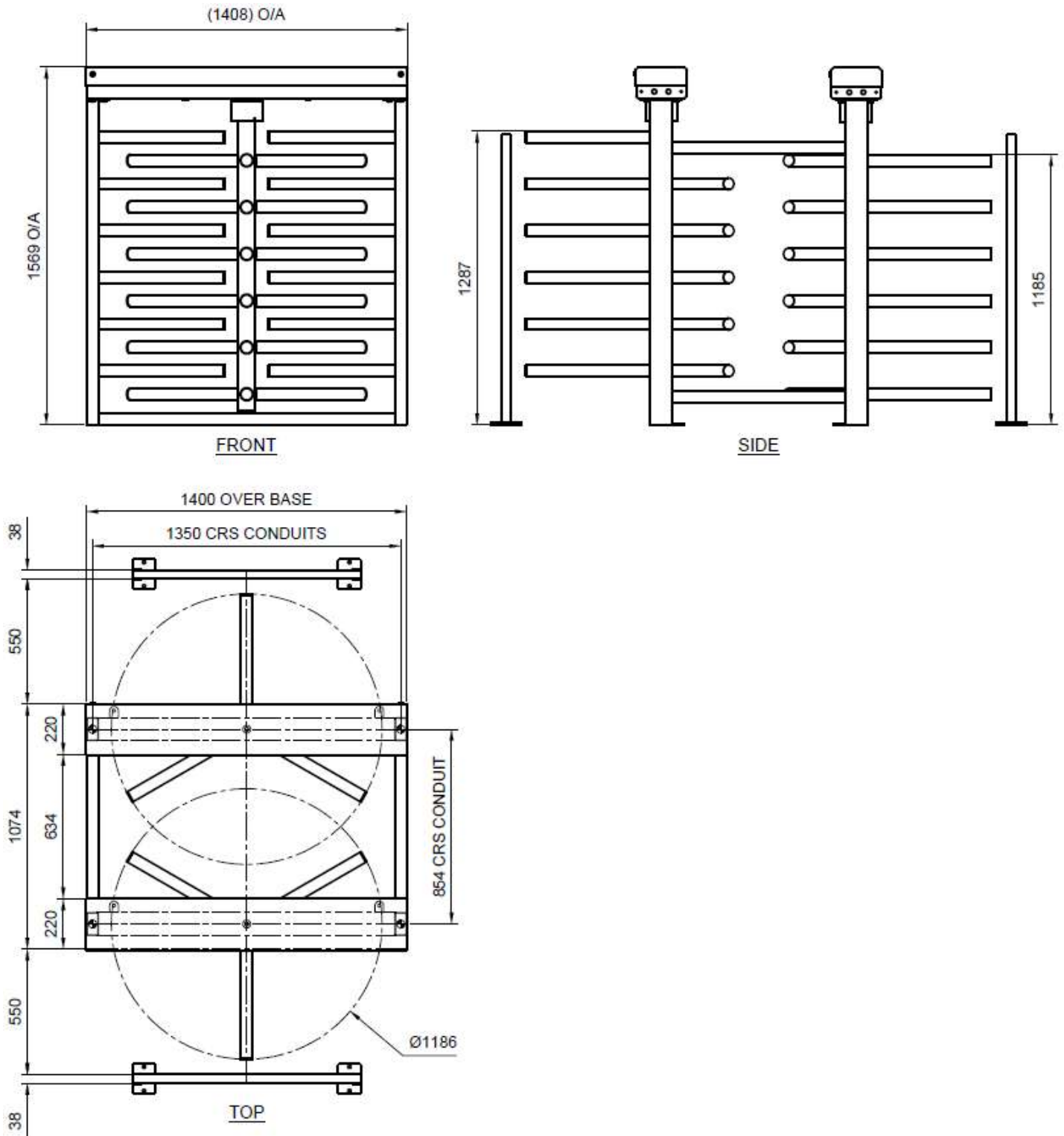

Figure 8: Double 3-Arm Industrial 3/4 Height Turnstile

3. GENERAL ASSEMBLY NOTES

3.1. Two people are recommended for assembling the product, but one person would be sufficient.

3.2. To assemble the product, the following tools are required for assembly.

- 5 Meter measuring tape
- Marker pen/ chalk
- Chalk line
- Hammer drill
- 16mm masonry drill bit
- M10 x 75mm coach bolts with nylon plug (8x for a single turnstile, 10x for a double turnstile)
- Hammer
- Spirit level
- 19mm flat spanner
- 24mm flat spanner
- Size 3 allen head key

4. **SINGLE PARTS & ASSEMBLY**

- 4.1. The single turnstile consists of 5 main parts, the frame, comb, channel, rotor, and cover.
- 4.2. Connect the frame with the channel and the comb as shown in *Figure 9: Single Frame Assembly*.
- 4.3. Bolt the top channel to the screens using the M12 bolts, washers and hexnuts. Ensure that the top cover locking plates and control channel chassis plate are also fixed during this process.

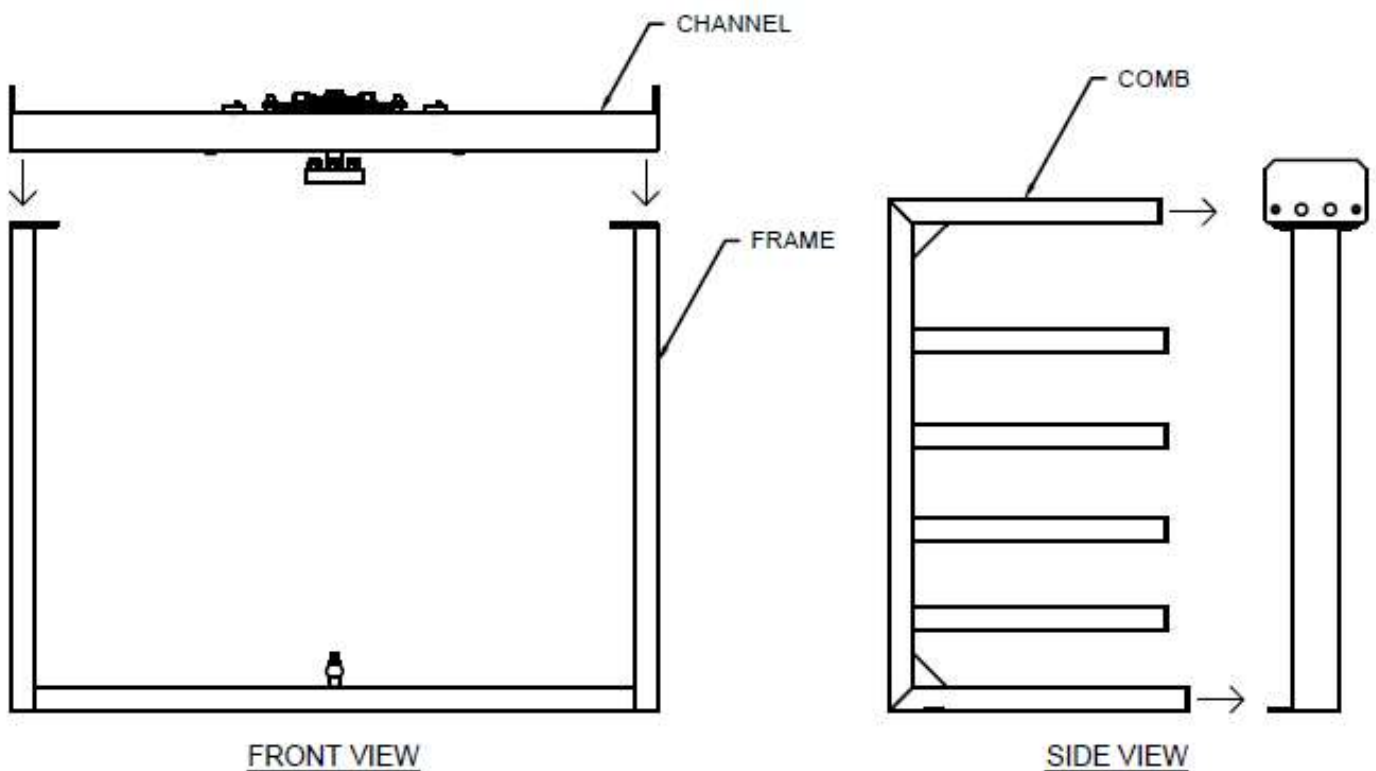

Figure 9: Single Frame Assembly

- 4.4. Ensure there is a level surface of 1500mm long x 1500mm wide to place the turnstile on.
- 4.5. Place the frame & comb as shown on drawing *Figure 10: Single Turnstile Plinth* with the frame edge 670mm from the end of the plinth. Bolt down the frame and comb using the 4x off holes.

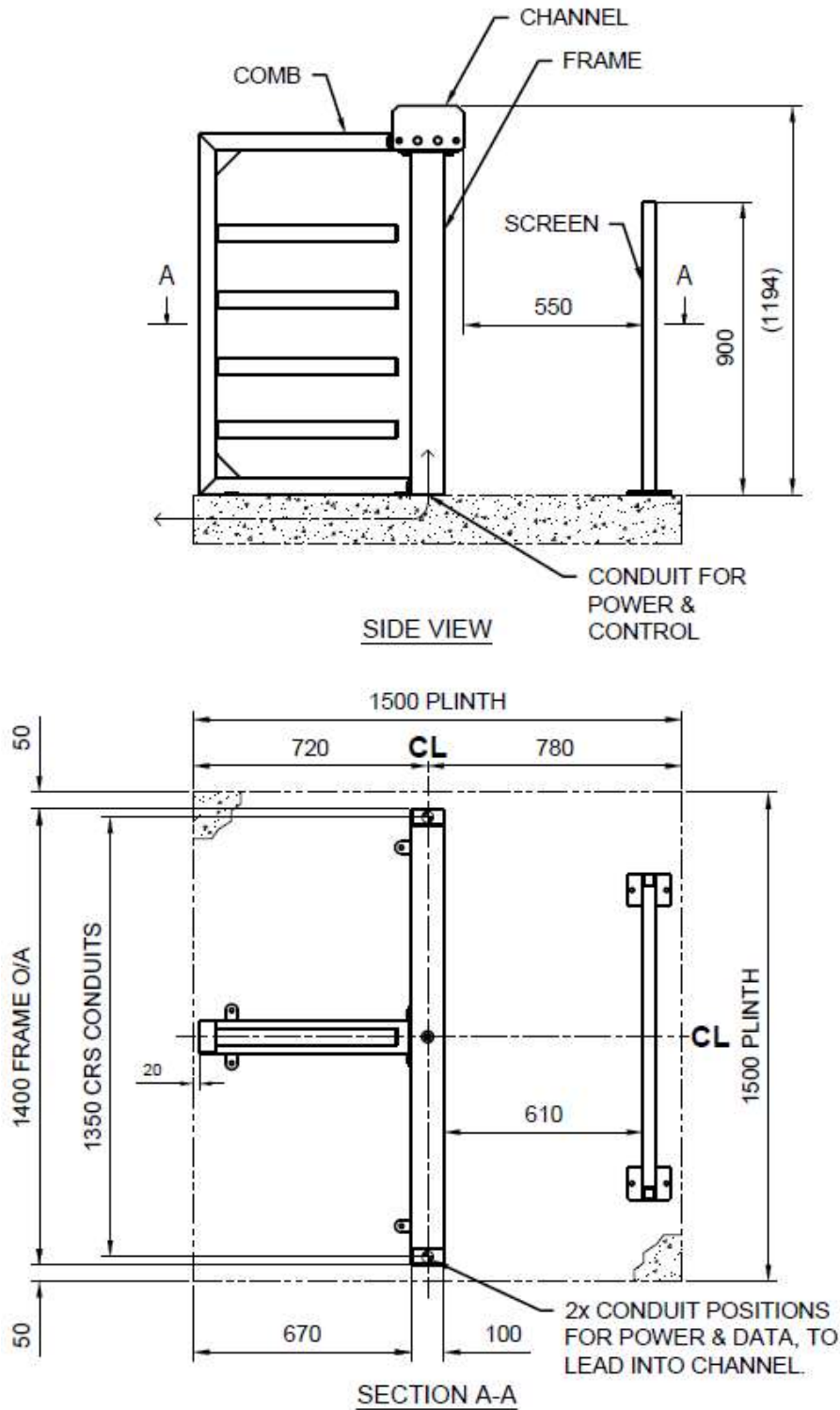

Figure 10: Single Turnstile Plinth

- 4.6. Loosen and remove the four M12 bolts which secure the mechanism to the top channel.
- 4.7. Slide the sleeve over the rotor top disk. Leave the sleeve loose without any fixing.

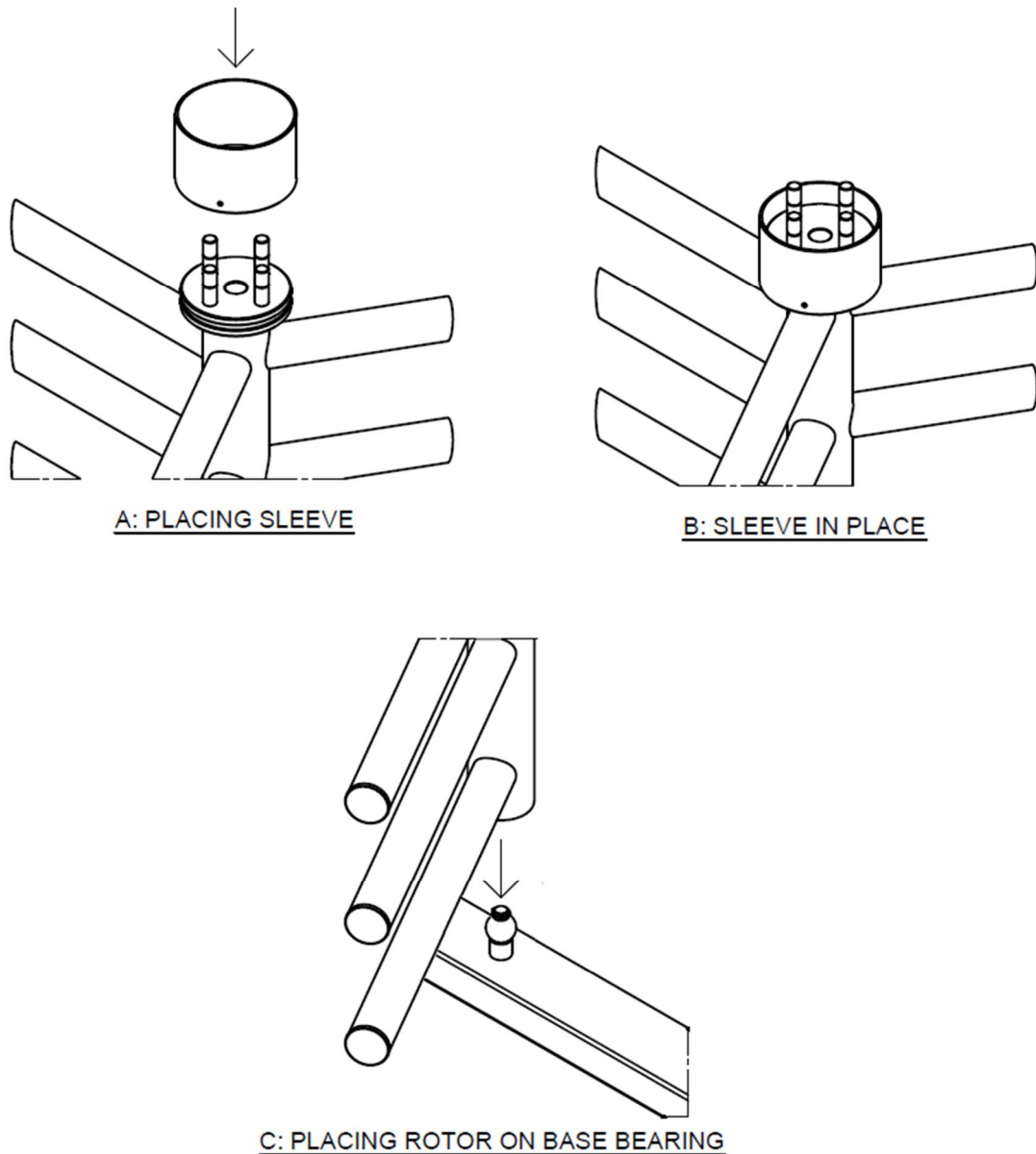

Figure 11: Sleeve and rotor on bearing pin

- 4.8. Place the base of the rotor onto the base bearing.
- 4.9. Lift the mechanism and align the rotor so that the mechanism rubber buffer disk slides onto the four M16 studs of the rotor top disk.
- 4.10. Reinsert and tighten the four M12 bolts which secure the mechanism to the top channel.

- 4.11. Place the bean washers over the M16 studs on the top disk and fasten using four M16 nylock hexnuts. Tighten each nut incrementally. As tightening is done, the rotor will be raised into position. Tighten until there is a 1mm gap between the rotor top disk and rubber buffer disk.
- 4.12. Raise the sleeve into position to cover the rotor coupling. Align and tighten the 4mm grub screws on the sleeve within recessed groove in the rotor top disk.

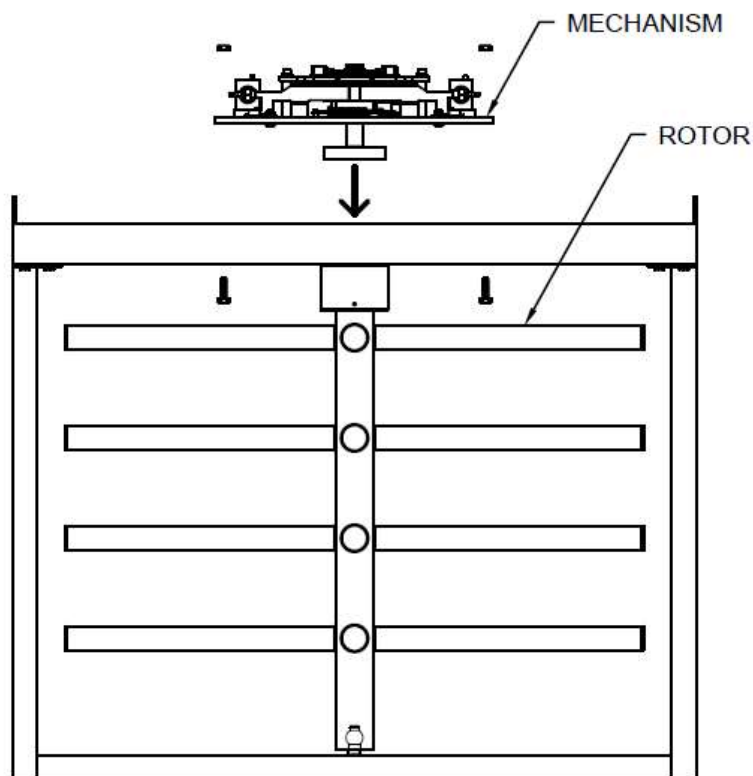

Figure 12: Mechanism & Rotor Connection

- 4.13. Fit the turnstile top cover in place and lock with the key provided.
- 4.14. Place the screen 610mm away from the uprights of the frame. The screen will be 550mm away from the end of the top channel. Bolt down the screen using the 4x off holes. See Figure 10: Single Turnstile Plinth.

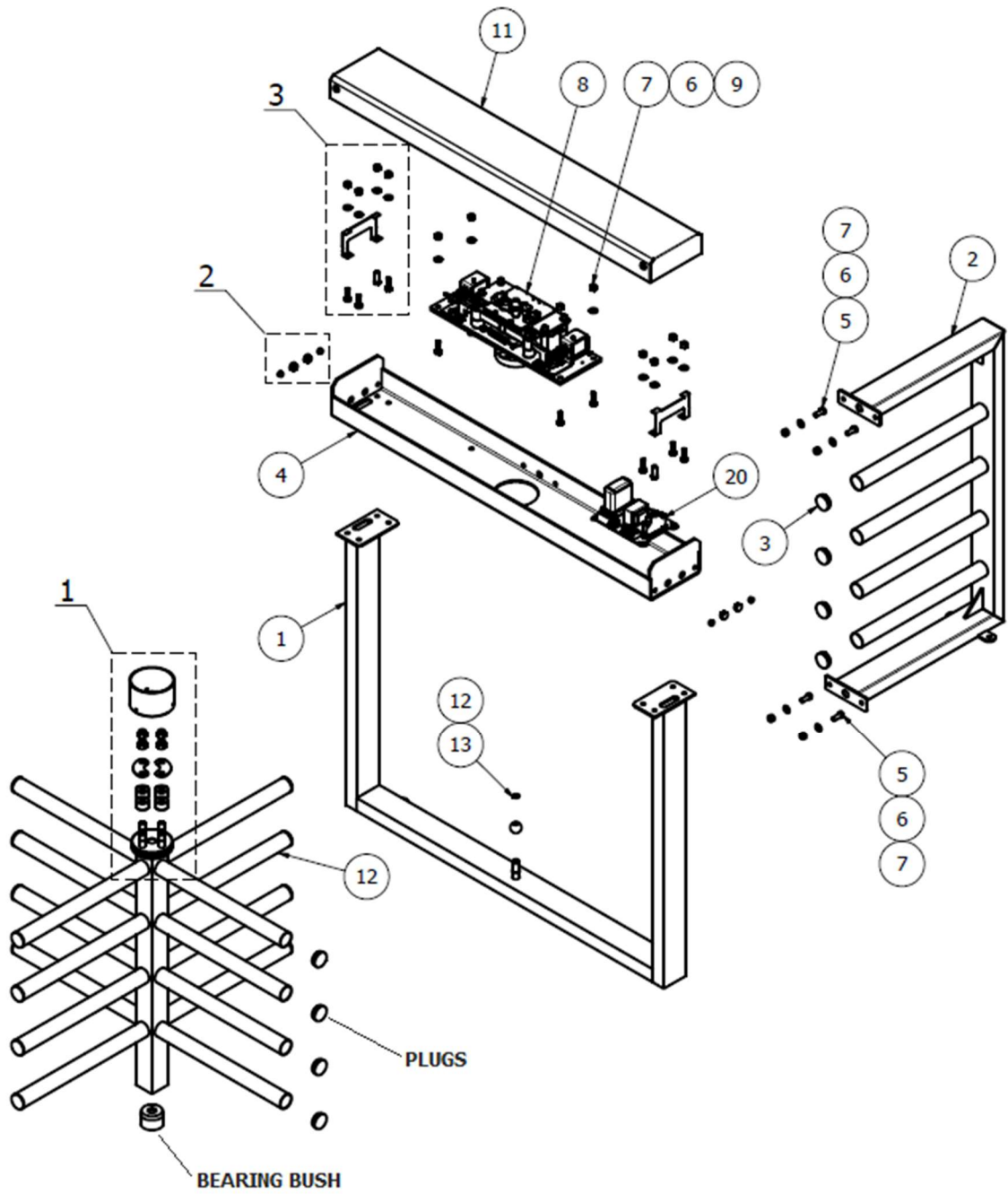

Figure 13: Single Half Height Exploded

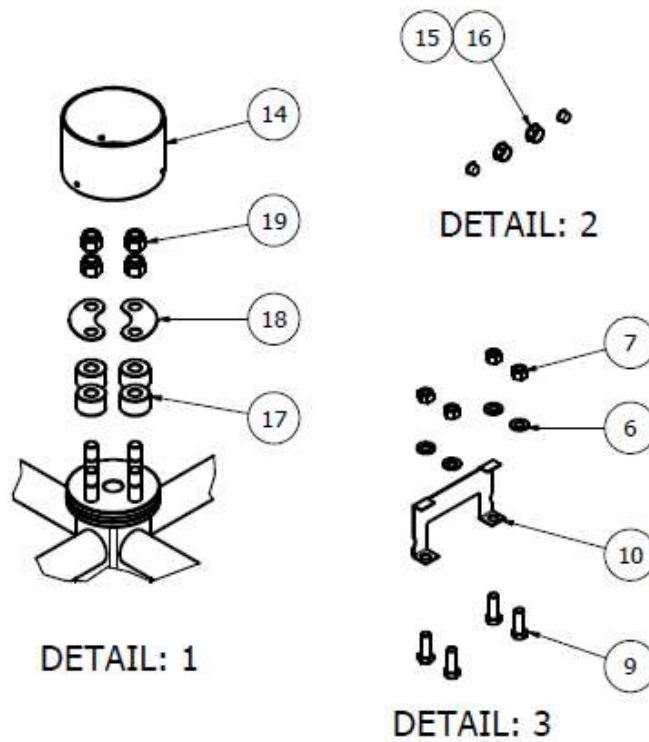

Figure 14: Detail of Exploded Parts

Table 1: Single Turnstile Parts

Item	Part Number	Description	Qty
1	HT-WM-02	Half Height Industrial Frame Weldment	1
2	HHT-WM-03	Half Height Comb Weldment	1
3	51-TP-CH	Tube Plug for 50,8 Tube, Black	4
4	HHT-WM-01	Half Height Channel Weldment	1
5	M12x30-HSS-ZP	M12x30 Hex Set Screw, 4.8, Zinc plated	4
6	M12x24-PFW-ZP	M12x24 Plain Flat Washer, Zinc plated	16
7	M12-HN-ZP	M12 Hex Nut, Zinc plated	16
8	TSM-AS-04	4-Arm Full Height Mechanism	1
9	M12x35-HSS-ZP	M12x35 Hex Set Screw, 4.8, Zinc plated	12
10	FHT-LC-29	Locking Plate	2
11	FHT-SA-03	Single Cover Assy	1
12	-	Rotor Assembly (3-arm or 4-arm)	1

13	17x1-CCEX-ZP	17x1 External Circlip, Zinc plated	1
14	FHT-SA-01	Top Disk Sleeve Assembly	1
15	13-PP-BL	Dia. 13 Internal Panel Plug, Black HDPE	4
16	20_22-DPP-BL	Dia. 20-22 Dome Panel Plug, Black HDPE	4
17	FHT-PT-02	Rubber Disk Buffer, 40 OD X 16 ID X 25mm	4
18	FHT-LC-33	Bean Washer	2
19	M16-NHN-ZP	M16 Nylock Hex Nut, Zinc plated	4
20	CP-AS-03	Full Height Control Panel Assy	1

5. **DOUBLE PARTS & ASSEMBLY**

- 5.1. The double assembly is similar to the single assembly. The double has two screens and a frame weldment, which accepts two rotors. The rotors mesh with the tubes on the frame.
- 5.2. Refer to installation of the single for tooling required, and how to place the rotors.
- 5.3. The double turnstile consists of 7 main parts, the frame, 2x off channels, 2x off rotors, and 2x off covers.
- 5.4. Bolt the top channel to the screens using the M12 bolts, washers and hexnuts. Ensure that the top cover locking plates and control channel chassis plate are also fixed during this process. See *Figure 15: Double Frame Assembly*.
- 5.5. Ensure there is a level surface of 2400mm long x 1500mm wide to place the turnstile on.
- 5.6. Place the frame as shown on drawing *Figure 16: Double Turnstile Plinth* with the frame centre on the plinth. Bolt down the frame and comb using the 4x off holes.

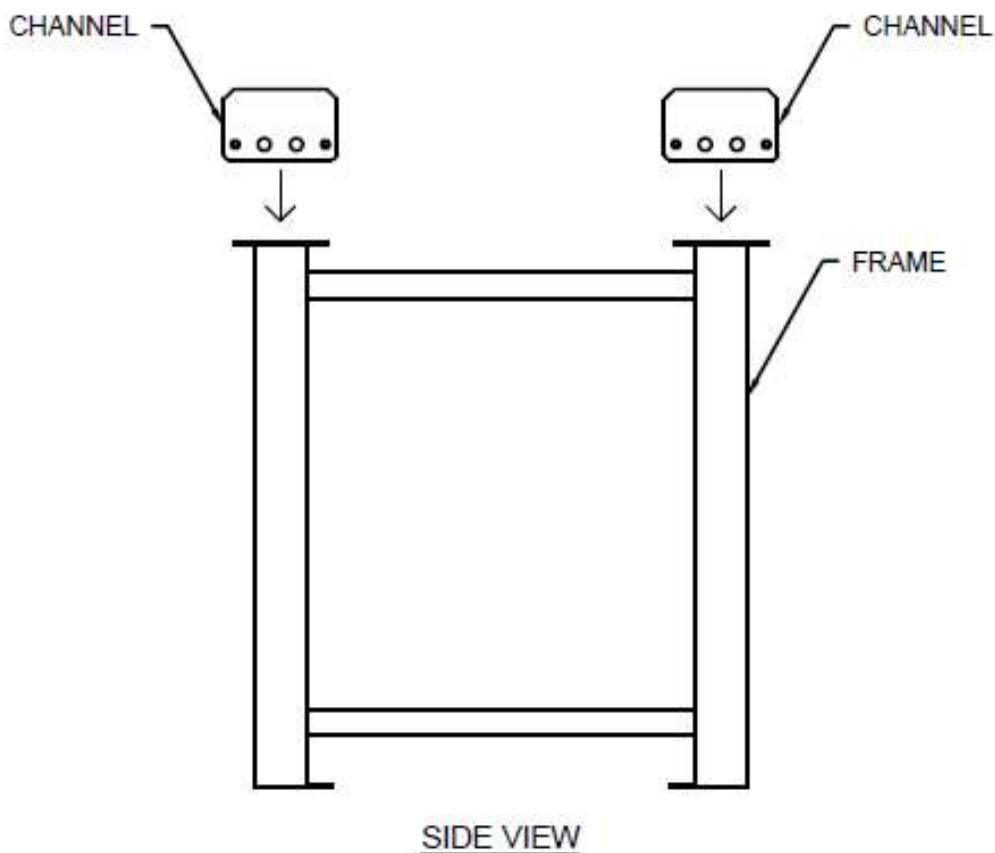

Figure 15: Double Frame Assembly

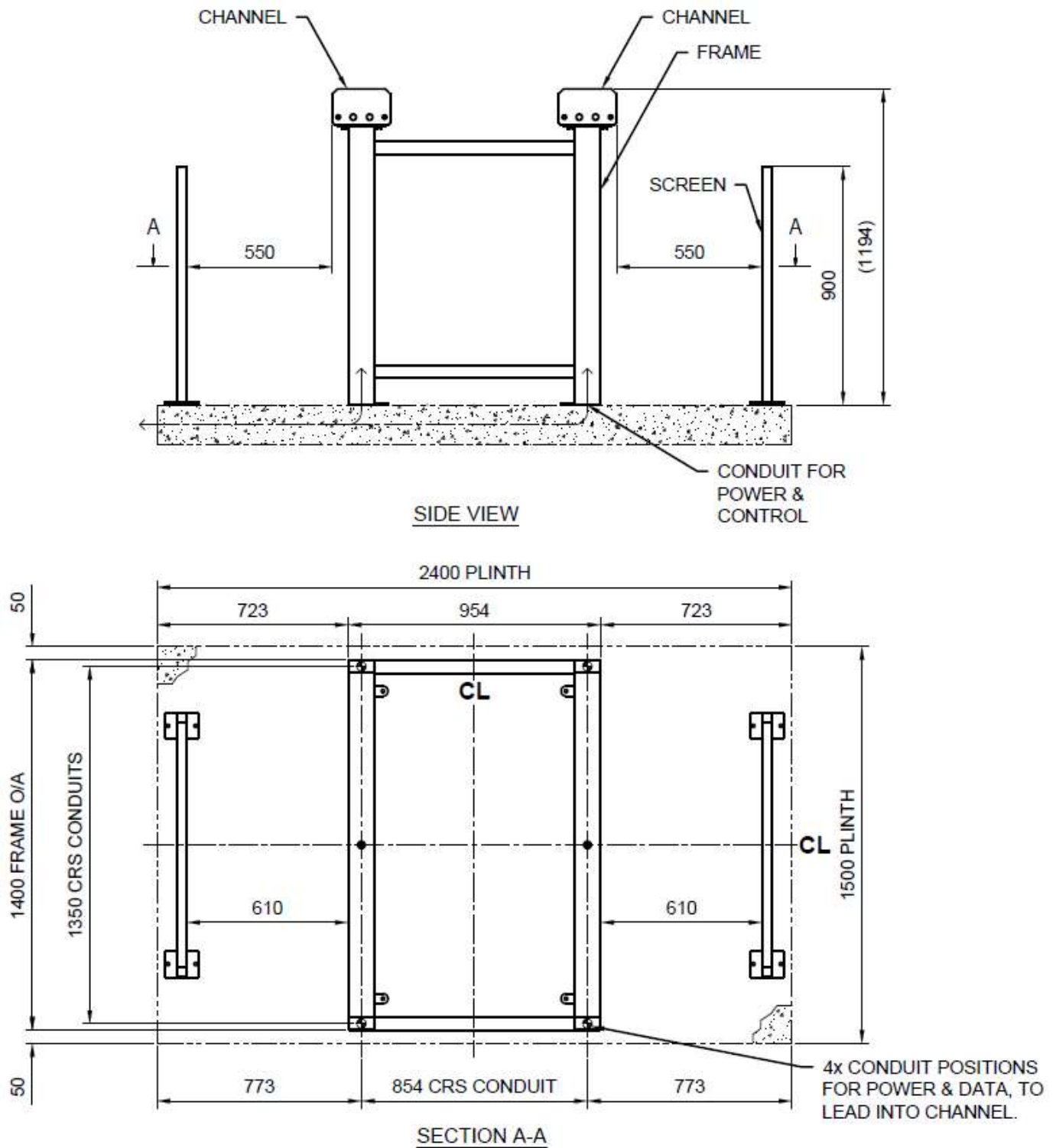

Figure 16: Double Turnstile Plinth

5.7. Place the rotors in position. (Refer to section 4.6 onward).

5.8. Place the screens 610mm away from the uprights of the frame. The screens will be 550mm away from the end of the top channels. Bolt down the screen. See *Figure 16: Double Turnstile Plinth*.

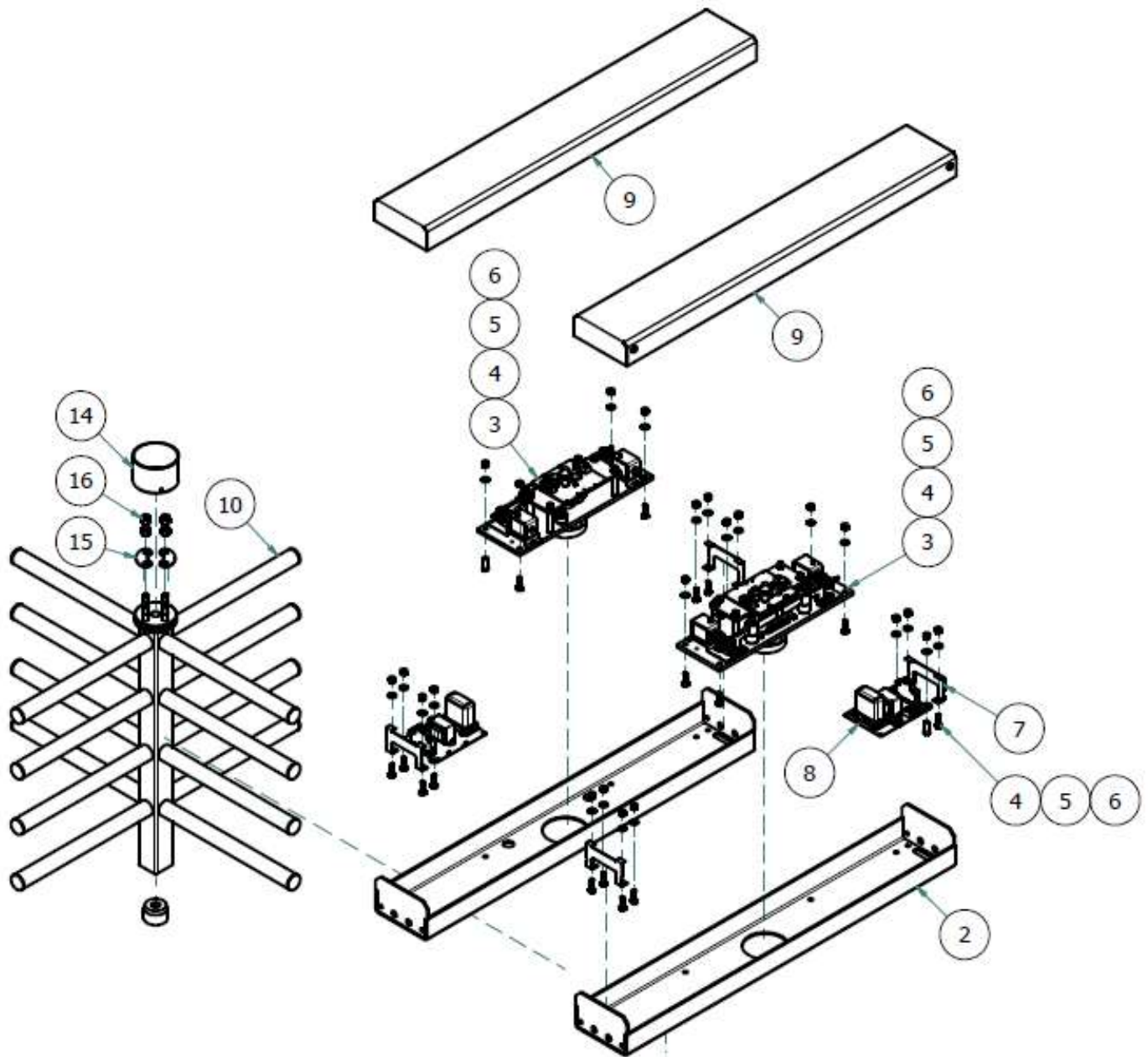

Figure 17: Double Turnstile Exploded Parts 1

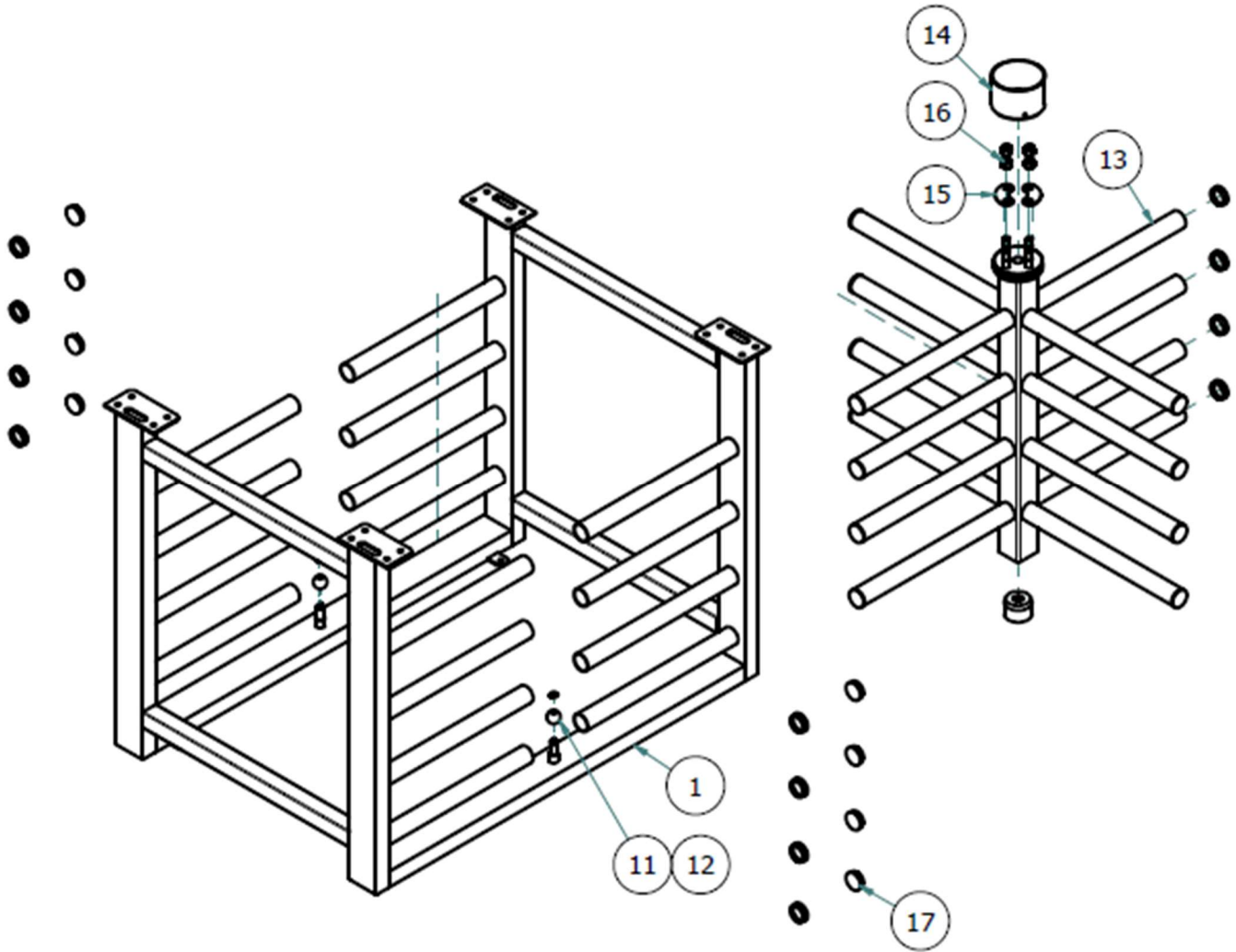

Figure 18: Double Turnstile Exploded Parts 2

Table 2: Double Turnstile Parts

Item	Part Number	Description	Qty
1	HT-WM-05	Half Height Industrial Double Frame Weldment	1
2	FHT-WM-03	Half Height Comb Weldment	2
3	TSM-AS-04	4-Arm FH Mechanism - Fail Secure	2
4	M12x35-HSS-ZP	M12x35 Hex Set Screw, 4.8, Zinc plated	24
5	M12x24-PFW-ZP	M12x24 Plain Flat Washer, Zinc plated	24
6	M12-HN-ZP	M12 Hex Nut, Zinc plated	24
7	FHT-LC-29	Locking Plate	4

8	CP-AS-03	Full Height Control Panel Assy	2
9	FHT-SA-03	Single Cover Assy	2
10	-	Half Height Industrial Rotor Assembly	1
11	FHT-MA-09	Bearing Sphere	2
12	17x1-CCEX-ZP	17x1 External Circlip, Zinc plated	2
13	-	Half Height 4-Arm Double Rotor Assembly	1
14	FHT-SA-01	Top Disk Sleeve Assembly	2
15	FHT-LC-33	Bean Washer	2
16	M16-NHN-ZP	M16 Nylock Hex Nut, Zinc plated	8
17	51-TP-CH	Tube Plug for 50,8 Tube, Black	16

6. FURTHER ROTOR ASSEMBLY INFORMATION

- 6.1. The rotor is suspended from the mechanism, and only requires a bearing sphere at the base to keep it centralised. See Figure 19: Views on Top Disk & Base Bearing, view 2. Lower the rotor onto the bearing sphere, with the rotor internal bush keeping it centric.
- 6.2. Place mechanism with rubber buffer disk onto the studded top disk of the rotor.
- 6.3. Lower the mechanism onto the rotor, so the mechanism shaft and rubber washers fit over the studs in the rotor disk, ensuring the rotor is aligned with one arm pointing directly toward the screen. Place the bean washers over the studs on the rubber buffers and the hex nylock nuts above the bean washer onto the top studs.
- 6.4. When tightening the nylock nuts, the rotor will lift. Tighten until the arms are aligned central between the arms of the comb. There should be a 1mm gap between the mechanism disk and the rotor top disk.
- 6.5. Lift the sleeve and tighten with the grub screws biting into the groove in the rotor disk.

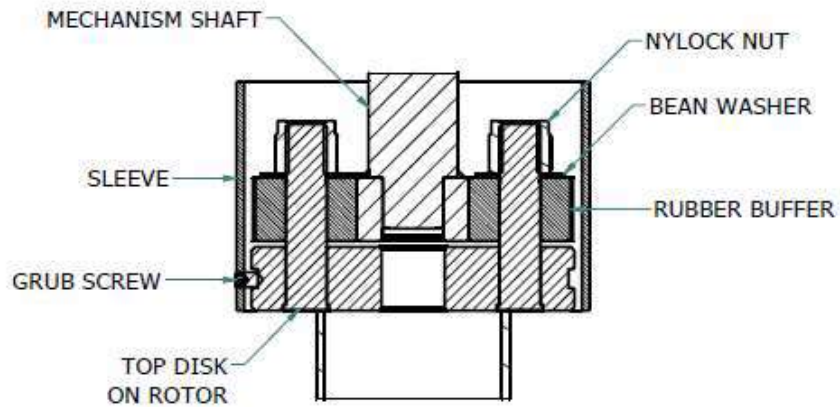

VIEW: 1
TOP DISK

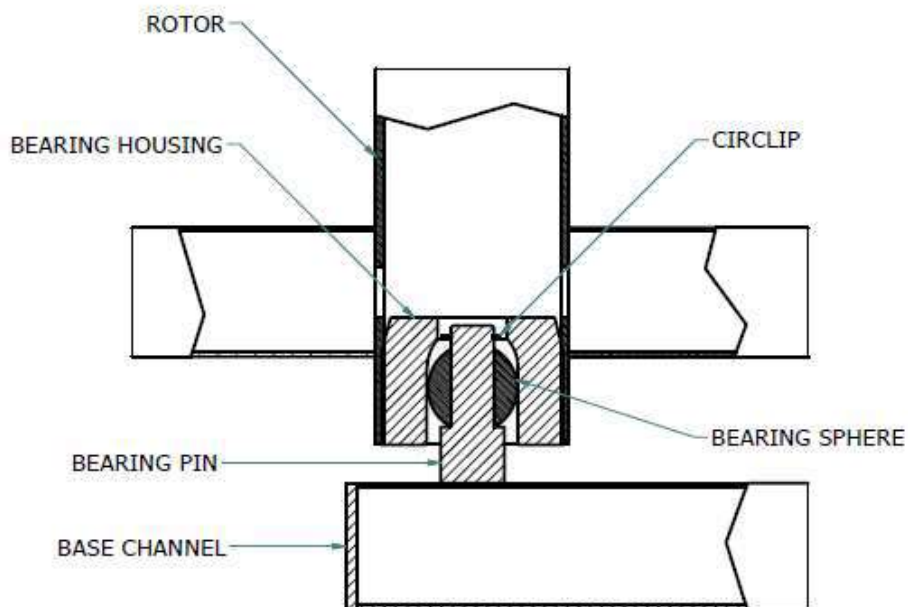

VIEW: 2
BASE BEARING

Figure 19: Views on top disk & base bearing

7. INSTALLATION

- 7.1. The turnstile must be secured in place on a level concrete plinth or tiled finished floor.
- Single Turnstile Specification: 1500mm long x 1500mm wide x 125mm deep, 15MPa strength concrete. (See *Figure 10: Single Turnstile Plinth*)
 - Double Turnstile Specification: 1500mm long x 2400mm wide x 125mm deep, 15MPa strength concrete. (See *Figure 16: Double Turnstile Plinth*)
- 7.2. Provision for power and data (where required) cabling must be made prior to the turnstile installation. Power and data cabling can enter the turnstile in one of four positions.
- Floor position A
 - Floor Position B
- 7.3. Recommendation: It is strongly recommended that the comb of a single turnstile be bolted to a robust structure, such as a wall or fencing post. This provides extra stability.
- 7.4. Position the assembled turnstile at the desired installation point.
- 7.5. Feed power and data cabling to the turnstile control panel.
- 7.6. Ensure the turnstile is level and positioned straight.
- 7.7. Bolt the turnstile to the floor using M10x75 coach bolts with nylon plug.
- 7.8. Note:
- The turnstile can be installed on floor tiles.
 - The turnstile cannot be installed directly onto brick paving as the bricks tend to crack during/-after installation.
 - When installing a security gate or fence beside the turnstile, the gate/-fence should not be welded to the turnstile. Welding damages the finish of the turnstile and can cause corrosion. If a fixing is required, the item can be bolted to the turnstile through the hole provided in the comb/-screen.

8. CONTROL PANEL & LOGIC

- 8.1. The control panel consists of a 220v AC power connection terminal, leading to an isolator. The isolator leads to an 18VAC transformer (sometimes 19V or battery backup) which distributes power to the printed circuit board and the plug-in logic. All the components are mounted onto a pre-galvanised chassis plate.
- 8.2. The plug-in logic controls the functions of the turnstile (The logic may differ from the image shown). See section 9.

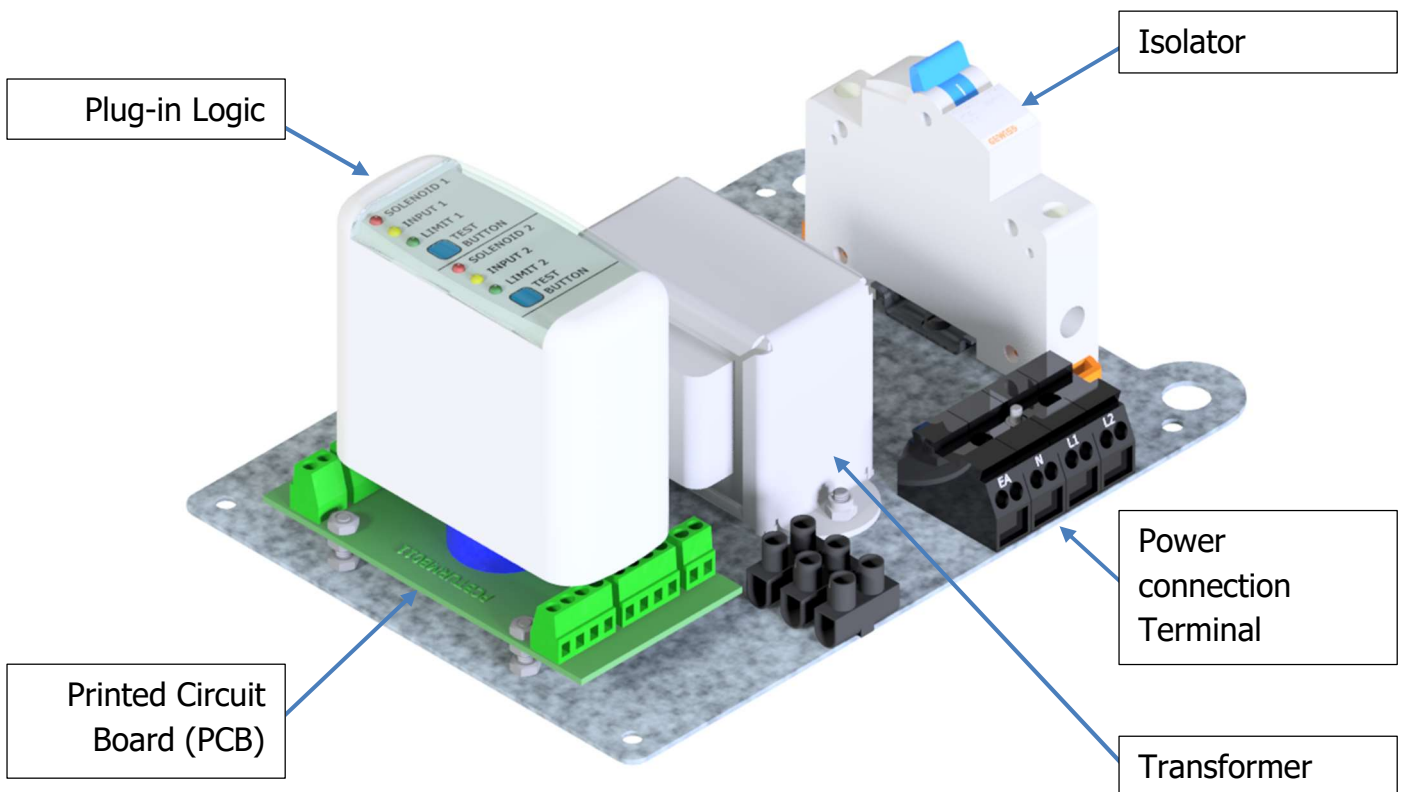

Figure 20: Turnstile control panel components

- 8.3. The trigger inputs on the logic are activated by a potential free contact (dry contact).
- 8.4. The limit switch inputs on the logic are activated by a potential free contact (dry contact).
- 8.5. The solenoid outputs on the logic are solid state MOSFET rated at 1,5A / 24VDC.
- 8.6. The EOT (End of transaction) outputs on the logic are normally open relays rated at 0,5A / 24 VDC.

9. TURNSTILE LOGIC TYPES

- 9.1. The control panel may be using one of two plug-in logics. Both logics have the same operation and features and are interchangeable. The grey logic (TURTL373) is mainly used locally in South-Africa and neighbouring countries. The blue logic (TL300TUR) is mainly used for exports to other countries.
- 9.2. The face of the logic incorporates two blue test buttons and six diagnostic LED indicators.
- 9.3. To test the grey logic, press one of the test buttons briefly.

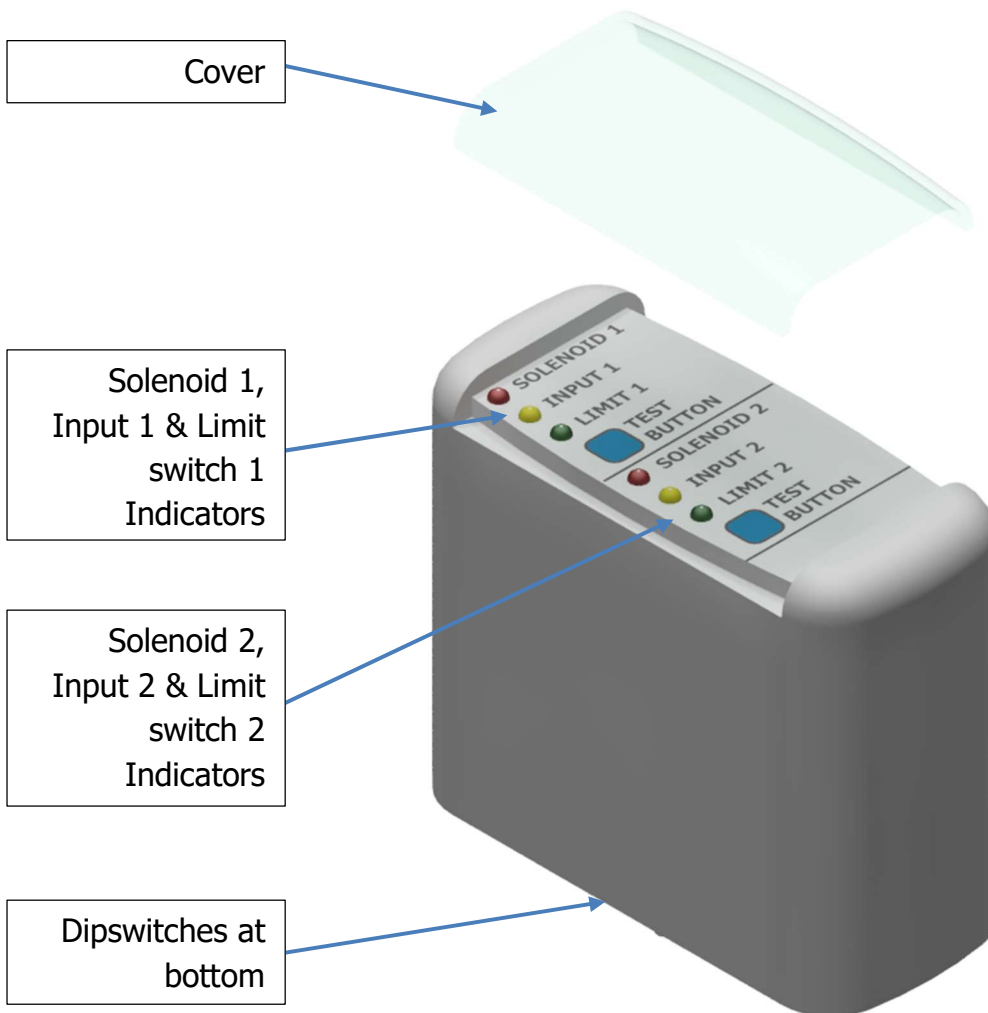

Figure 21: Grey Plug-in Logic (TURTL373)

- 9.4. The blue logic (TL300TUR) has a section showing feedback LED, dipswitches under a flip open cover and a toggle switch for testing. The feedback section shows when the logic has power, when an entry trigger is received and when an exit trigger is received. The toggle switch must always be in the centre for automatic mode.
- 9.5. To test the grey logic, flip the toggle switch briefly to either 'in' or 'out' and return it to the centre.

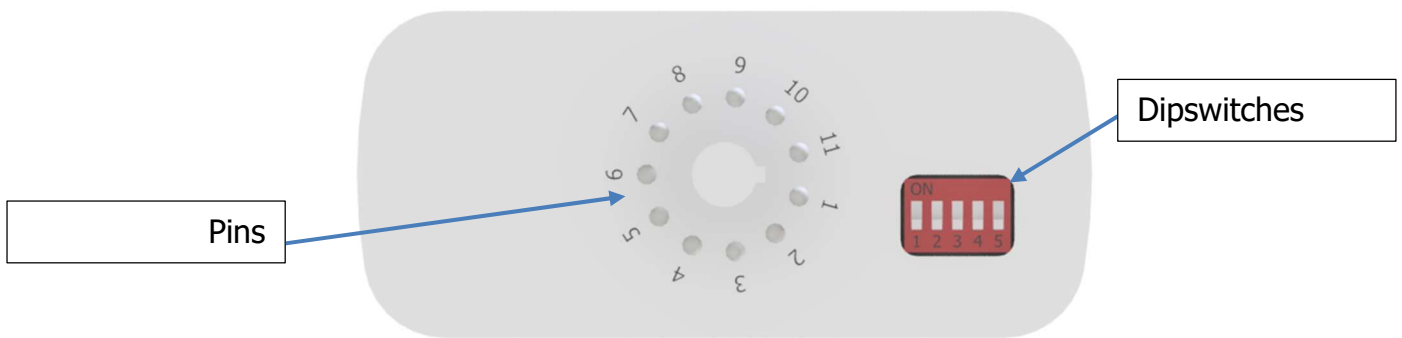

Figure 22: Base of Grey Plug-in Logic (TURTL373)

Table 3: TURTL373 Logic Dipswitch Settings

Switch No.	Function	ON	OFF
5	Sound	On	Off
4	Solenoid 2	Fail-Secure	Fail-Safe
3	Solenoid 1	Fail-Secure	Fail-Safe
2	Input 2 (Direction 2) (Fire Alarm)	Extended Trigger	Once-off Trigger
1	Input 1 (Direction 1) (Fire Alarm)	Extended Trigger	Once-off Trigger

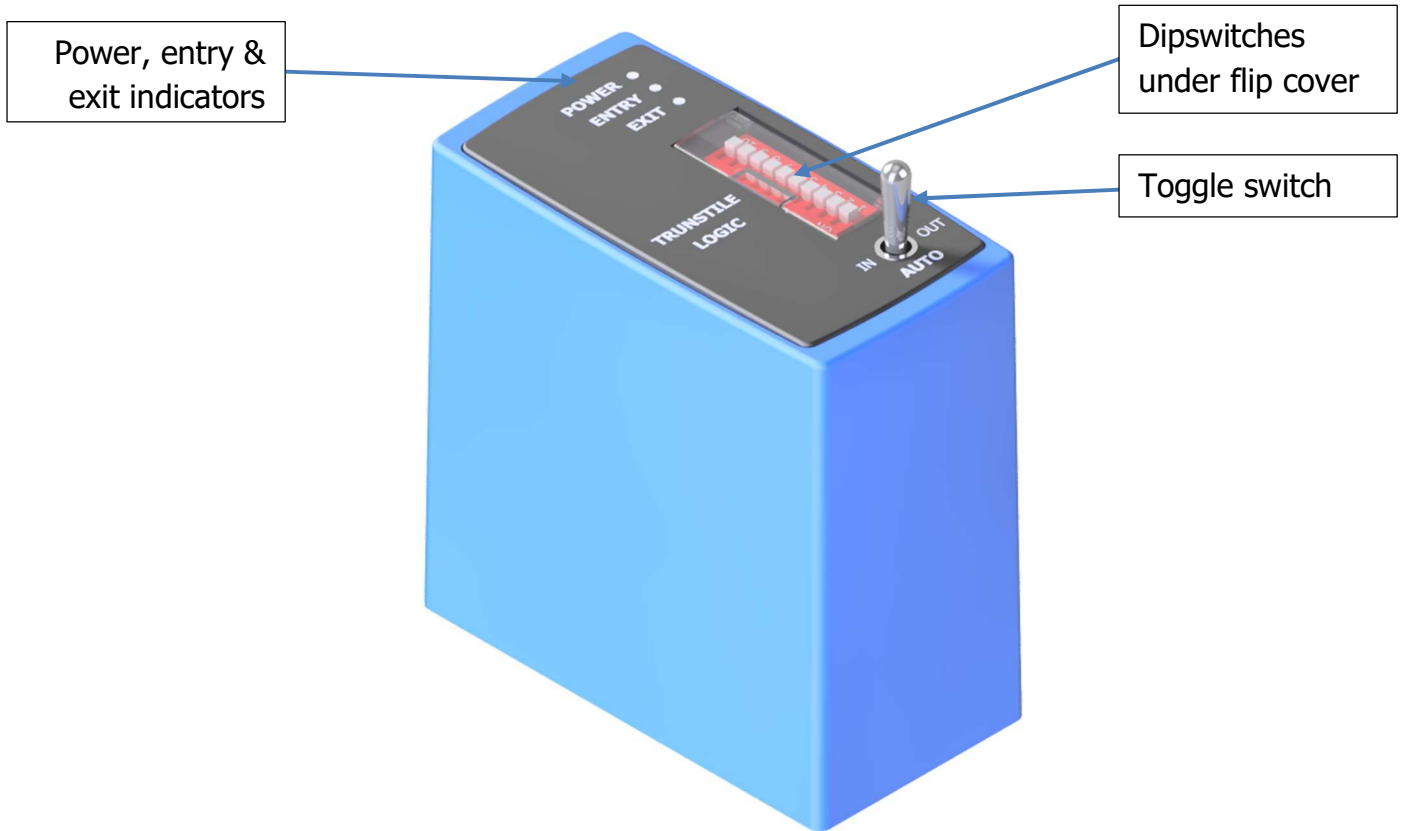

Figure 23: Blue Plug-in Logic (TL300TUR)

Table 4: TL300TUR Logic Dipswitch Settings

Switch No.	Function	ON	OFF
10	Not used	Reset	Off
9	Not used	-	Off
8	Timeout	10 Sec.	20 Sec.
7	Trigger memory	On	Off
6	Exit trigger latch	Enable	Off
5	Entry trigger latch	Enable	Off
4	Relay output mode	LED / Buzzer mode	Transaction Complete Mode
3	Entry/ Exit trigger input	N/C	N/O
2	Exit Solenoid	Fail Safe	Fail Secure
1	Entry Solenoid	Fail Safe	Fail Secure

10. WIRING DIAGRAMS

10.1. The control panel consists of a 220v AC power connection terminal, leading to an isolator. The isolator leads to the transformer which distributes 18VAC power to the printed circuit board and the plug-in logic. All the components are mounted to a pre-galvanised plate.

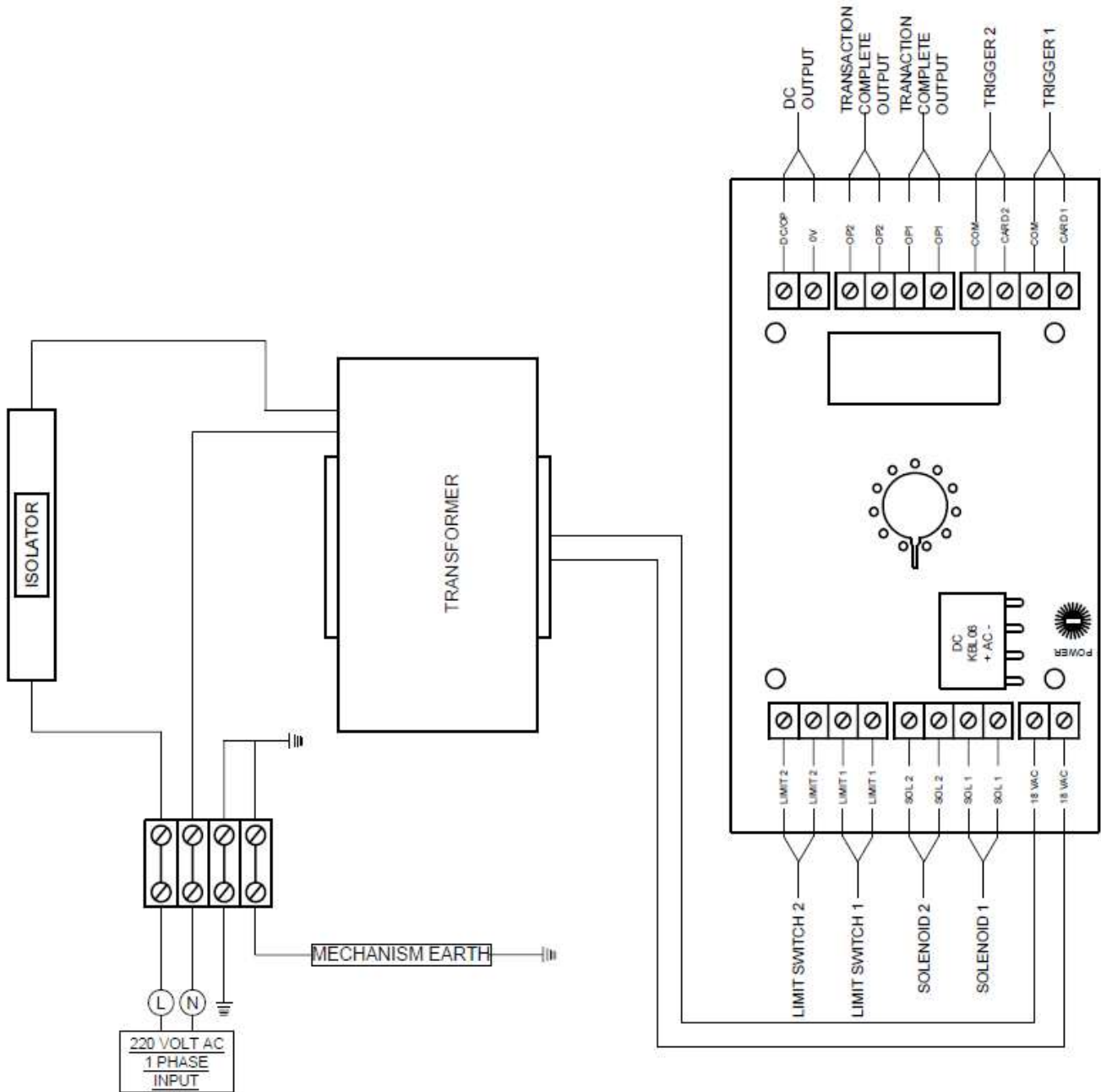

Figure 24: Wiring Diagram for Full Height Turnstile

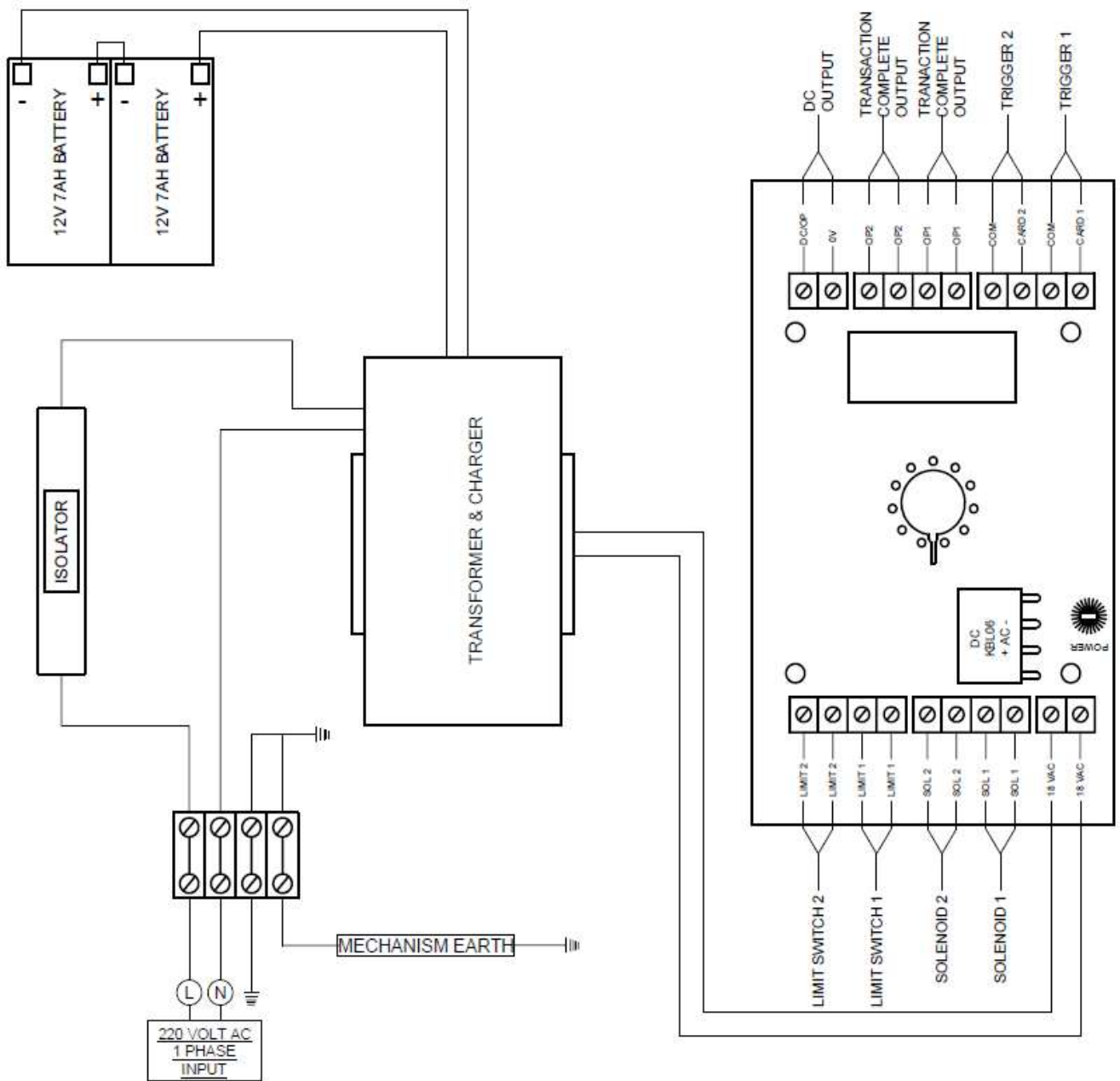

Figure 25: Wiring Diagram for FH Turnstile with Battery Backup

11. STANDARD FACTORY SETUP

- 11.1. Ensure mains power is switched off.
- 11.2. Connect the mains power cable to the turnstile controller at the power connection terminal.
- 11.3. Connect the access control relay output to the triggers on the PCB (Trigger 1 and Trigger 2), one for each direction. The trigger to unlock the turnstile is a dry-contact, potential free input. The closing signal should be no longer than 0,5 seconds.
- 11.4. Switch on the mains power.
- 11.5. Check that mains power is being distributed to the control board.
- 11.6. Test the turnstile unlocking by triggering the access control system. Confirm the direction that is being opened is correct as required by the access control. If it is not, swap the trigger inputs on the control panel.
- 11.7. When triggering, walk through the turnstile. When exiting, the turnstile rotor will lock, not allowing further entry. Repeat this for the opposite direction.
- 11.8. If the turnstile does not trigger from the access control system, test the logic using the button or toggle provided.

12. **MAINTENANCE**

- 12.1. If the grey logic is used (TURTL373), ensure dipswitches 1 & 2 is switched **ON**. When giving an extended trigger to either trigger 1 or trigger 2 from the access control, the turnstile will be open, and any number of pedestrians can pass through. The turnstile will remain open until the extended trigger is removed.
- 12.2. If the blue logic is used (TL300TUR), ensure dipswitches 6 and 7 is switched **ON**. When giving an extended trigger to either trigger 1 or trigger 2 from the access control, the turnstile will be open, and any number of pedestrians can pass through. The turnstile will remain open until the extended trigger is removed.

13. **FAIL-SECURE AND FAIL-SAFE**

- 13.1. The turnstile mechanism can be configured either in fail-safe or fail-secure. The default factory setting is fail-secure.
- 13.2. A fail-safe mechanism configuration unlocks the rotor to freely rotate in the case of a power-failure.
- 13.3. A fail-secure mechanism configuration locks the rotor in case of power failure. In this case, if the rotor is required to be unlocked, this can be done by unlocking the mechanical over-ride with the key provided.



Figure 26: Solenoid in Fail-secure arrangement

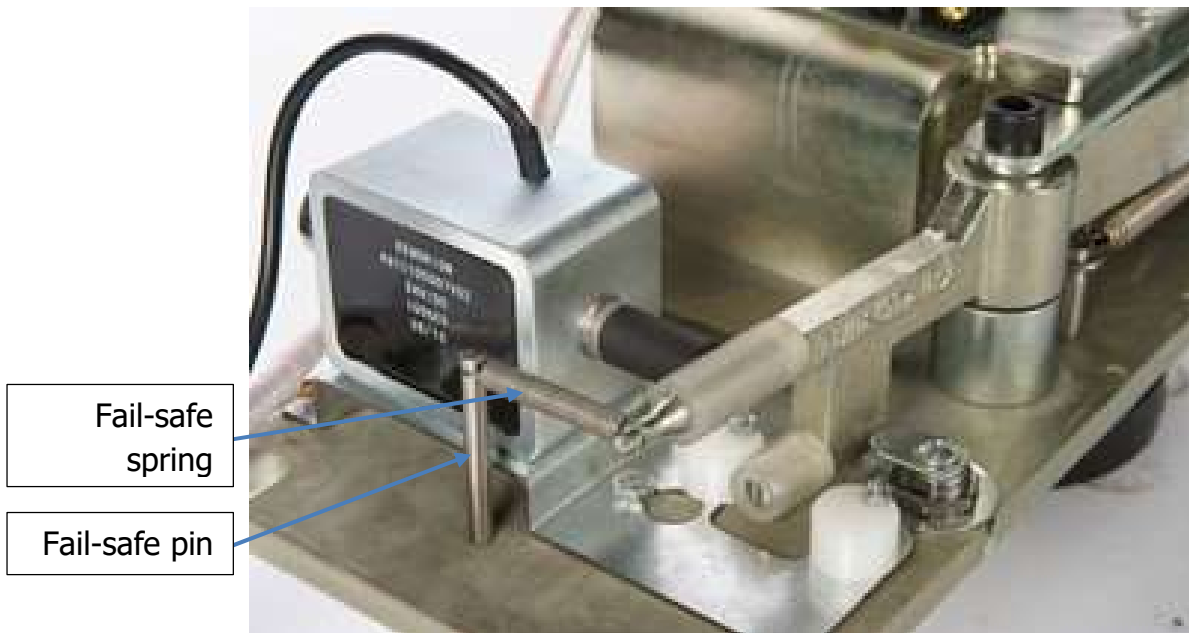
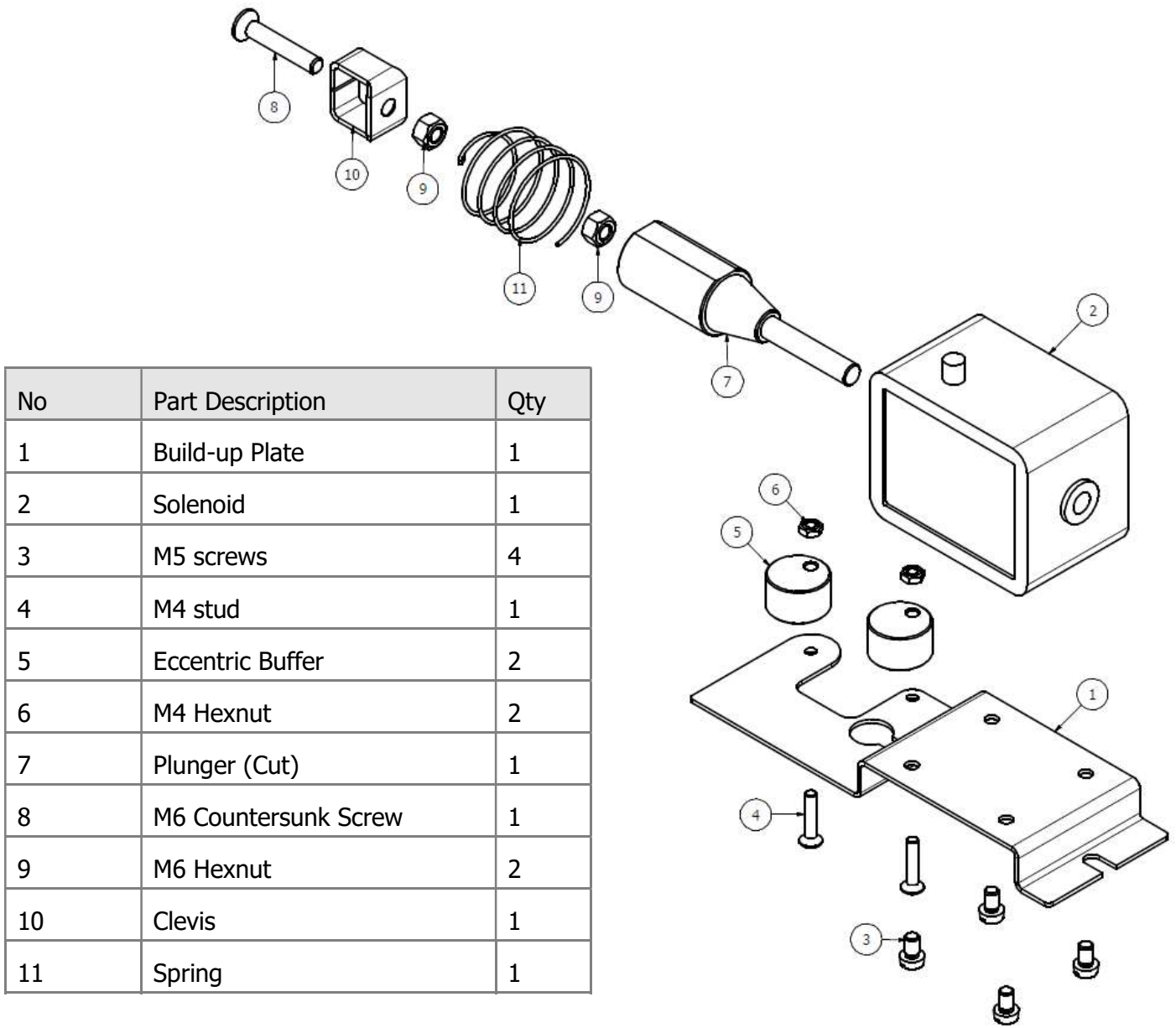

Figure 27: Solenoid in Fail-safe arrangement

- 1.1. If fail-safe, a solenoid is 'pushing' on the pawl when under power. When in fail-secure, a solenoid is pulling when under power.
- 1.2. For **Fail-Secure** setting, on the logics,
 - Grey Logic (TURTL373) – Ensure dipswitches 2 and 3 are **ON**.
 - Blue Logic (TL300TUR) – Ensure dipswitches 1 and 2 are **OFF**.
- 1.3. For **Fail-Safe** setting, on the logics,
 - Grey Logic (TURTL373) – Ensure dipswitches 2 and 3 are **OFF**.
 - Blue Logic (TL300TUR) – Ensure dipswitches 1 and 2 are **ON**.



No	Part Description	Qty
1	Build-up Plate	1
2	Solenoid	1
3	M5 screws	4
4	M4 stud	1
5	Eccentric Buffer	2
6	M4 Hexnut	2
7	Plunger (Cut)	1
8	M6 Countersunk Screw	1
9	M6 Hexnut	2
10	Clevis	1
11	Spring	1

Figure 28: Solenoid assembly – Fail-secure

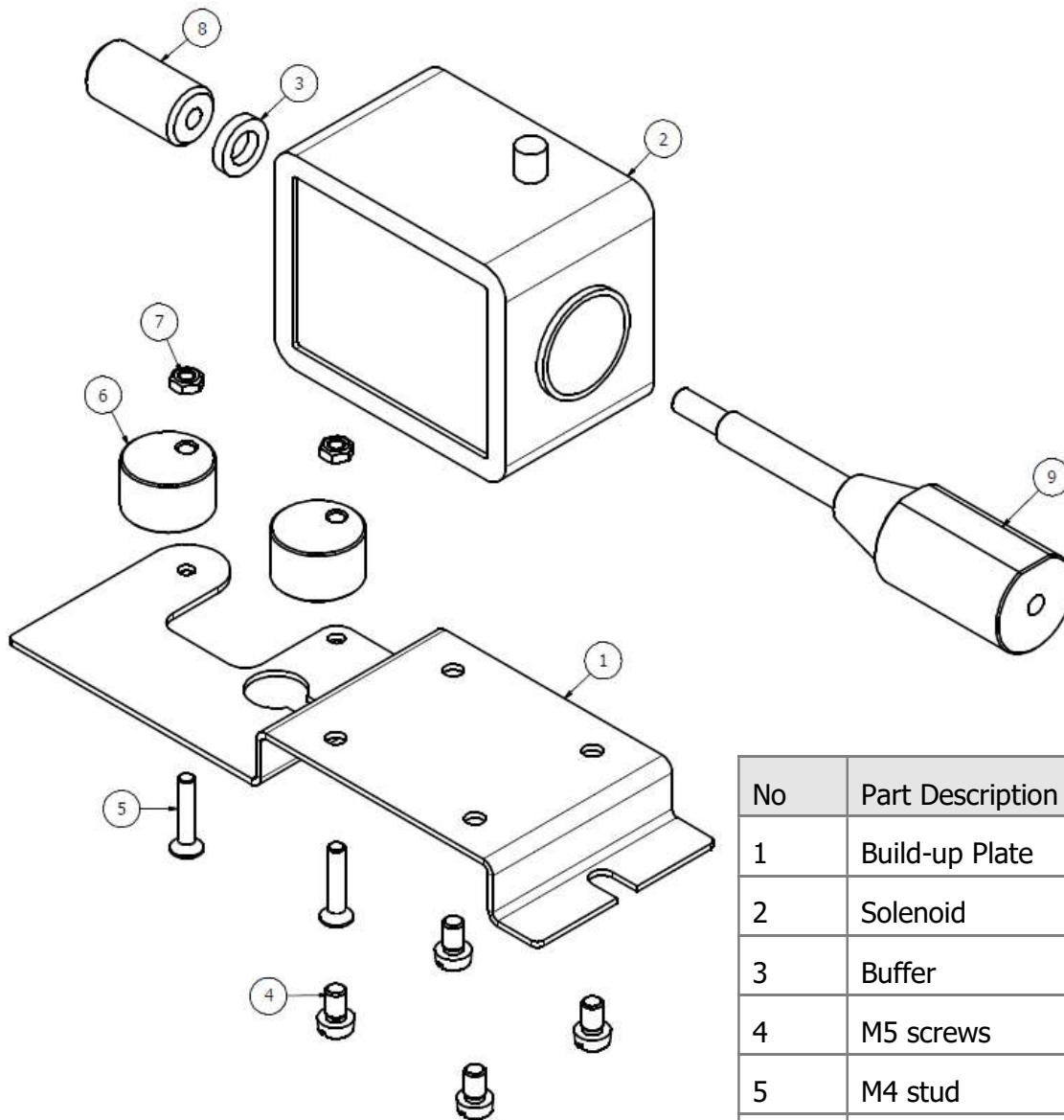

No	Part Description	Qty
1	Build-up Plate	1
2	Solenoid	1
3	Buffer	1
4	M5 screws	4
5	M4 stud	1
6	Eccentric Buffer	2
7	M6 Hexnut	2
8	Cam	1
9	Plunger	2

Note, when placing the fail-safe solenoid build up, also install the fail-safe pin and spring to the pawl, shown in Figure 27.

Figure 29: Solenoid assembly – Fail-safe

14. MAINTENANCE

14.1. The recommended maintenance interval is every 12 months.

Table 5: Recommended Maintenance Procedure

No	Part Description	Check
1	Cleaning of all external powder coated surfaces	
2	Checking fixing and functionality of all turnstiles keyed locks in top cover and for mechanism (key 60198)	
3	Cleaning of turnstile mechanism and top channel	
4	Checking of turnstile mechanism pawl settings and application of grease to pawls and locking disk	
5	Checking of turnstile solenoid operation & positioning and cleaning with alcohol	
6	Microswitch adjustment, if necessary (2x microswitches)	
7	Checking of turnstile battery backup system	
8	General functionality: Enter turnstile and become trapped. Trigger for access to be granted and finish the entry (do this for both clockwise and anti-clockwise directions)	
9	General functionality: Enter turnstile and become trapped. Allow for time-out and return to the outside position (do this for both clockwise and anti-clockwise directions)	
Turnstile Serial Number:		
Date of maintenance:		
Maintenance carried out by:		
Turnstile Serial Number:		
Date of maintenance:		
Maintenance carried out by:		

15. CLEANING

- 15.1. Depending on the finish of the turnstile, different cleaning instructions will apply.
- 15.2. Dusting – Dust turnstile with a feather duster or soft cloth.
- 15.3. Wash – Cleaning of turnstile to be done with a soft cloth (non-abrasive) dipped into a mixture of warm water and mild dishwashing liquid (alkaline-based cleaner with a pH of 12 or lower). Then rinse the turnstile with clean water. Do not spray with high pressure water near the top channel as water can damage the internal electronics.

Table 6: Recommended Cleaning Frequency

Type	Action
Powder-coated mild steel	Dust once a month
	Wash stubborn dirt in the affected area
Hot-dipped Galvanised mild steel	Dust once a month
	Wash stubborn dirt in the affected area
304/316 grade stainless steel	Wash the entire turnstile twice a month with warm soapy water and a soft cloth
Powder-coated 304/316 grade stainless steel	Dust once a month
	Wash stubborn dirt in the affected area

16. SPARE PARTS

16.1. The below table shows the suggested spare parts to keep on hand for servicing the turnstile or to repair the turnstile in an emergency.

Table 7: Spare Parts List

Part Description	Qty
Transformer	1
Battery Backup UPS power supply	1
Battery	2
PC Board	1
Plug-In Logic (Ultitech or Procon)	1
Microswitch	2
Solenoid	2
Lock with Key	2
Lock cam	2
Indexing Roller	1
6mm Key	1
Clevice	2
Fail-secure spring	2
Fail-safe spring	2

17. FAULT FINDING

Fault	Cause	Solution
Turnstile rotates continuously, even without power.	The over-ride lock might be unlocked with the key.	The over-ride lock might be unlocked with the key.
Turnstile does not unlock automatically on power failure when in fail-safe mode.	The mechanism is not set-up for fail-safe.	Check if the mechanism is set-up for fail-safe operation.
	The logic is not set for fail-safe operation.	Set the logic for fail-safe operation.
Turnstile unlocks automatically on power failure when in fail-secure mode.	The mechanism is not set-up for fail-secure.	Check if the mechanism is set-up for fail-secure operation.
	The logic is not set for fail-secure operation.	Set the logic for fail-secure operation.
Turnstile does not unlock.	Solenoid needs cleaning.	Clean solenoid with alcohol. No Q20 allowed to be used for cleaning.
Turnstile rotor does not self-centre.	Indexing spring broken.	Replace indexing spring.
3-arm Turnstile trapping you	Assembly is wrong.	Check the rotor assembly and correct.
4-arm Turnstile trapping you.	Microswitches are wired incorrect.	Correct wiring on microswitches.
Batteries are not charging.	Battery output voltage incorrect.	Check output of battery backup UPS power supply and adjust output voltage to 27,6v.
Turnstile is on but does not rotate on trigger activation.	Trigger not received by control panel.	Isolate where the fault could be. Test the turnstile using either the test pushbuttons or toggle switch provided on the plug-in logic.
	Access control trigger faulty.	Check for continuity on the access control trigger.
	Possible faulty PC board.	Trigger either card 1 or card 2 terminals to isolate if there is a fault on the PC board.
Turnstile allows more than 1 person to go through at a time.	Trigger signal extended.	Check if the fire-alarm settings are active and check the length of trigger

		activation. The signal may be too long and should be $\frac{3}{4}$ of a second or less.
	Faulty microswitch.	Check if a microswitch is faulty or broken. Replace microswitch.
Arms of turnstile are colliding or scraping against the comb.	Rotor lowered.	Check mechanism. The circlip may be damaged, and the rotor may have dropped.